

James Jensen, BPhil

Finite-dimensional Hopf algebras

Supervised by Associate Professor John Bamberg.

This thesis is presented for the partial requirements of the degree of
Bachelor of Philosophy with honours of the University of Western Australia.

Submitted October 17, 2025.

Corrections made on December 25, 2025.

Abstract

This thesis expounds the theory of finite-dimensional Hopf algebras, with particular emphasis on their representation theoretic properties. Beginning in the general context of monoidal categories, we present the definition of a Hopf monoid as a natural generalization of the concept of a group, an instance of the general category theoretic process known as internalization. We also explore additional structures on monoidal categories such as the existence of duals or an internal hom. After introducing the representation theory of finite-dimensional algebras, including a full treatment of the Jordan-Hölder and Krull-Schmidt theorems, we provide a second motivation for the definition of Hopf algebras via an informal account of Tannaka duality. We finish by exploring how Hopf algebras allow us to generalize the construction of McKay quivers, certain directed graphs originally constructed from the representations of finite groups. A particular feature of our treatment is the use of string diagrams throughout, a generalization of Feynman diagrams, which aid in visual intuition and greatly facilitate proofs.

Acknowledgements

First of all, I would like to thank my supervisor John Bamberg for his continued confidence and support throughout this project, even as I was blown wildly off course from my original research topic in group representation theory into the realm of 'abstract nonsense.'¹ Before commencing Honours, I was lucky enough to undertake an undergraduate research placement and then an AMSI Summer Research Scholarship with John, the first covering finite geometry and the latter on vertex operator representations of affine Kac-Moody algebras. I am immensely appreciative of John's versatility as a mentor who has been happy to guide me as I traversed such a wide range of topics.

I would like to thank my parents for their continued belief in me and support during these four years of study at the University of Western Australia.

¹ A term used by many for category theory with varying levels of affection.

Contents

0	<i>Introduction</i>	1
	0.1 <i>Conventions</i>	3
1	<i>Preliminaries</i>	5
	1.1 <i>Category theory</i>	5
	1.2 <i>Linear algebra</i>	13
	1.3 <i>Quivers</i>	16
2	<i>Extra structure on categories, and internalization</i>	19
	2.1 <i>Monoidal categories and vertical categorification</i>	19
	2.2 <i>Monoids, first definition</i>	24
	2.3 <i>String diagrams in monoidal categories</i>	25
	2.4 <i>Monoids, second definition</i>	26
	2.5 <i>Comonoids</i>	28
	2.6 <i>Modules</i>	30
	2.7 <i>Bimonoids</i>	31
	2.8 <i>Internalizing groups: Hopf monoids</i>	31
	2.9 <i>Closed categories</i>	34
	2.10 <i>Dual objects and autonomous categories</i>	35
	2.11 <i>The pivotal symmetric category $\text{Vect}_{(\mathbb{K})}$</i>	37
	2.12 <i>Ideals</i>	41
	2.13 <i>A menagerie of Hopf algebras</i>	43
3	<i>Representation theory</i>	47
	3.1 <i>Representations of groups</i>	48

3.2	<i>Representations of \mathbb{K}-monoids</i>	51
3.3	<i>Tannaka duality</i>	57
3.4	<i>Representations of Hopf algebras</i>	59
3.5	<i>Bimonoid and Hopf faithful representations</i>	61
4	<i>McKay quivers of finite-dimensional Hopf algebras</i>	65
4.1	<i>Cartan duality</i>	66
4.2	<i>A conjecture</i>	67
4.3	<i>Nonclassical examples of McKay quivers</i>	68
5	<i>Conclusion</i>	73
A	<i>Abelian categories</i>	75
B	<i>SageMath code</i>	79
	<i>Bibliography</i>	83
	<i>Symbols</i>	89
	<i>Abbreviations</i>	93
	<i>Index</i>	95

List of Figures

1.1	A schematic representation of a very simple category.	5
1.2	Relationship between different kinds of morphism in a category.	6
1.3	Morphisms in the product categories.	7
1.4	Universal property of the unit of adjunction	12
1.5	Universal property of the coünit of adjunction	12
1.6	Universal property of the binary coproduct	12
1.7	The universal property of the product	13
1.8	Universal property of the quotient module.	14
1.9	The first isomorphism theorem via the universal property of the quotient module	14
1.10	The universal property of the tensor product	15
1.11	Universal property of the free module.	16
1.12	Constructing the universal morphism for the tensor product from a quotient of a free module.	16
1.13	An example quiver.	17
2.1	Equivalent braids in \mathfrak{B}_3 .	21
2.2	Equal composite morphisms in a monoidal category.	26
2.3	The multiplication for the opposite monoid.	28
2.4	The comultiplication for the coöpposite comonoid.	29
2.5	String diagrams for the bimonoid compatibility conditions.	31
2.6	A morphism commuting with antipodes.	32
2.7	The antipous is a monoid antihomomorphism	33
2.8	The right dual of a morphism.	36
2.9	The evaluation and coëvaluation for the tensor product of dualizable objects.	36
2.10	A Feynman diagram.	37
2.11	Constructing closed monoidal evaluation from rigid evaluation.	37
3.1	Commutative diagram for the intertwiner condition.	49
3.2	Lifting property of a projective module.	51
3.3	Jordan-Hölder decomposition of a CDih_6 -module.	53
3.4	Factorization of a representation via a quotient bimonoid.	62
3.5	Factorization of a representation via a quotient group.	62
3.6	Constructing a nonzero Hopf ideal from a normal subgroup.	62
4.1	The McKay quiver of $\text{PSL}_3(2)$ at $V(3,0) = V(3,1)^*$.	65
4.2	The Cayley graph of Dih_6	68
4.3	The McKay quiver of \mathcal{D}_4 at $V(2,0)$.	70

4.4 The McKay quiver of \mathcal{D}_5 at $V(1,1)$. 71

A.1 A split exact sequence. 78

O

Introduction

The interplay between the classical and the quantum is central in modern physics, and it enjoys at least two parallels in modern mathematics. The first is the relationship between commutativity and noncommutativity, in the spirit of the noncommutative geometry of Connes and the free probability of Voiculescu.¹ The basic concepts of both classical and quantum mechanics are states and observables. In the classical case, the states correspond to points in *phase space* M and the observables are elements of $C^\infty(M)$, the space of smooth functions on M . In the quantum case, the states are 1-dimensional subspaces of a Hilbert space V and observables are elements of $\text{End}_{\mathbb{C}}(V)$, the space of linear operators on V . In both cases the observables form an algebra under multiplication, the key difference being that classical observables commute while their quantum mechanical counterparts may not. For example, the classical phase space of a 1-dimensional massive particle is \mathbb{R}^2 , with the two fundamental observables being the coordinate functions of x and p for position and momentum respectively. After quantization, the operators \hat{x} and \hat{p} obey the Heisenberg commutation relation $[\hat{x}, \hat{p}] = i\hbar$, the classical limit corresponds to $\hbar = 0$. The observables \hat{x} and \hat{p} can be viewed as functions on a *noncommutative* space known as a *quantum plane*.² Thus “quantization is something like replacing commutative algebras by noncommutative ones.”³

A second parallel is found in the relationship between cartesian and monoidal categories, as first observed by Abramsky.⁴ A significant difference between the classical and quantum worlds is the impossibility of duplicating an unknown quantum state, a result known as the *no-cloning theorem* with far-reaching implications in quantum computing. In light of the Curry-Howard-Lambek correspondence, quantum computing and its linear logic belong to the semantics of general closed monoidal categories, while classical computing and its intuitionistic logic belong to the semantics of the narrower class of cartesian closed categories.⁵ The no-cloning theorem has a category theoretic analogue in Fox’s theorem, discussed in §2, which implies that a (symmetric) closed monoidal category is cartesian if and only if it is equipped with a canonical way to duplicate and delete data.⁶

Hopf algebras, first introduced by algebraic topologist Heinz

¹ Connes, *Noncommutative Geometry*; Voiculescu, Stancu, and Weber, *Free Probability and Operator Algebras*.

² Lesniewski, “Noncommutative Geometry.”

³ Drinfel’d, “Quantum Groups,” p. 798.

⁴ Abramsky, “No-Cloning in Categorical Quantum Mechanics.”

⁵ Baez and Stay, “Physics, Topology, Logic and Computation.”

⁶ Fox, “Coalgebras and Cartesian Categories.”

Hopf for studying the homology of compact Lie groups, intersect with both of these parallels. Hopf algebras are themselves of importance in theoretical physics, in particular in their connection to *quantum groups*. These are not groups *per se*, but do arise as the symmetries of quantized systems in a similar vein to groups. According to Drinfel'd, "the notions of Hopf algebra and quantum group are in fact equivalent, but the second one has some geometric flavour."⁷ Hopf algebras have also found applications in both classical and quantum computation, and linguistics;⁸ as well as other areas of mathematics such as integrable systems, Galois theory, combinatorics, and knot theory.⁹

A large part of this thesis is dedicated to motivating the slightly mysterious notion of Hopf algebra such that the reader may feel they could have come up with it themselves. We give two alternate explanations for the ubiquity of Hopf algebras, both of which play out in the formalism of monoidal categories. After reviewing necessary preliminaries of basic category theory and linear algebra in §1, we establish the general setting of monoidal categories in §2. String diagrams, a generalization of the diagrammatic formalisms of Feynman and Penrose, play an important role in our exposition of monoidal categories from the outset, and the diagrammatic reasoning they provide affords us more intuitive and efficient proofs. Thus this thesis also serves as a general introduction to the notation of string diagrams for monoidal, braided monoidal, and rigid categories. Our first motivation for introducing the notion of Hopf algebra proceeds by *internalizing* the concept of a monoid to a general monoidal category, investigating the corresponding dual structure termed a *comonoid*, and then using these observations to internalize the structure of a group. Thus Hopf algebras are presented as a natural generalization of a group to non-cartesian contexts.

A second motivation for Hopf algebras is presented in §3 using an informal account of Tannaka duality, which studies the interplay between an algebraic structure and its category of representations. In pursuit of the most general class of structures whose category of representations has certain nice properties in common with representations of groups, we recover precisely the definition of a Hopf algebra. The same chapter gives an introduction to the general representation theory of finite-dimensional algebras, with proofs of fundamental results such as the Jordan-Hölder and Krull-Schmidt theorems. Particular emphasis is given to the divergence of the representation theory of general algebras from that of semisimple ones, and how the representation theoretic properties of an algebra are captured by its Grothendieck groups. We investigate possible generalizations of the notion of a faithful group representation to that of a Hopf algebra, in particular that of Hopf faithful and bi-monoid faithful modules, the latter being a novel strengthening of the former concept due to Banica and Bichon.¹⁰

Finally, §4 applies these results to the motivating problem of McKay quivers. In their original form due to John McKay these

⁷ Drinfel'd, "Quantum Groups," p. 800.

⁸ Underwood, *Fundamentals of Hopf Algebras*; de Felice, "Hopf Algebras in Quantum Computation"; Marcolli, Chomsky, and Berwick, *Mathematical Structure of Syntactic Merge*.

⁹ Drinfel'd, "Quantum Groups"; Chase and Sweedler, *Hopf Algebras and Galois Theory*; Aguiar and Mahajan, *Monoidal Functors, Species, and Hopf Algebras*; Underwood, *Fundamentals of Hopf Algebras*.

¹⁰ Banica and Bichon, "Hopf Images and Inner Faithful Representations."

were directed graphs summarizing the decomposition of products of group representations into indecomposables.¹¹ Consideration of the most general context in which this construction makes sense was what originally lead the author to this vast subject, and almost everything in this thesis was learnt over the past eight months as a result. Thus a naïve form of Tannaka duality was unconsciously at play from the beginning.

§§3 and 4 contain a number a small contributions to the representation theory of Hopf algebras, including a conjecture on the connectivity of McKay quivers of Hopf algebras and an observation relating McKay quivers to Cayley graphs. A computable implementation of the Grothendieck group for an infinite family of noncommutative noncocommutative Hopf algebras is also described, and used to generate some interesting examples of McKay quivers.

0.1 Conventions

All results in this work are well-known unless otherwise specified. Theorems which are original are marked with a \star , see e.g. proposition 3.35. All proofs are my own, except for those with citation, see e.g. proposition 2.25.¹²

\mathcal{K} will always be a commutative ring and \mathbb{K} a (commutative) field. Occasionally additional hypotheses such as algebraic closure or special characteristic are applied to \mathbb{K} . All rings are unital, a structure like a ring which may lack a unit is a rng.

The partial application of a map is denoted by a question mark $?$, for example if $f : \mathbb{R}^2 \rightarrow \mathbb{R}$ is the function defined by $(x, y) \mapsto x + 2y$, then $f(?, 5) = ? + 10 : \mathbb{R} \rightarrow \mathbb{R}$ is the function defined by $x \mapsto x + 10$, and the map $f(?, ?)$ is identical to f . Also, we denote the underlying function of an infix operator as $(*) = ? * ?$.

Occasionally in this work we will need to invoke **multisets**, which can be thought of as sets that can have multiple copies of the same element, i.e. multiplicity. An n -element multiset M with elements in S is the same as an equivalence class in S^n modulo permutation of entries.¹³ As such, a set containing 3 copies of a , 2 copies of b , and 1 copy of c may variously be denoted

$$M = [a, a, a, b, b, c] = [a, b, c, a, b, a] = [b, a, c, b, a, a] = \&c.$$

We call $\{a, b, c\}$ the underlying set of M , and say $x \in M$ iff x is an element of this underlying set.

We endeavour to distinguish those conditions which are only *sufficient* from those which are also *necessary* by using the abbreviation “iff” for “if and only if” whenever applicable, including definitions.

¹¹ McKay, “Graphs, Singularities, and Finite Groups.”

¹² Side notes are used liberally throughout this thesis to add context to statements, fill in gaps in sketches of proofs, and remind the reader of definitions.

¹³ i.e. an orbit in S^n under the action of the symmetric group S_n .

1

Preliminaries

1.1 Category theory

Throughout this work, we will find it convenient to use the language of *category theory*. Here we introduce the fundamental notions of categories, functors, natural transformation, and adjunction, among others. The definitions used are taken from Mac Lane, Richter, Aluffi, and Awodey.¹

1.1.1 Categories

A **category** C consists of a class² $\text{Ob}(C)$ of *objects*, and for any two objects $X, Y \in \text{Ob}(C)$, and a set³ of *morphisms* $C(X, Y)$, called a **hom-set**, satisfying the following properties

1. Given morphisms $f \in C(X, Y)$ and $g \in C(Y, Z)$ there is a *composition law* giving $g \circ f \in C(X, Z)$, where we often drop the circle in favour of juxtaposition $gf = g \circ f$;
2. For every object X of C there exists a (provably unique) morphism $1_X \in C(X, X)$ called the *identity* on A , such that for any object Y of C and any morphisms $f \in C(X, Y)$, $g \in C(Y, X)$ we have $f1_X = f$ and $1_Yg = g$;
3. The composition law is *associative*, namely for $f \in C(X, Y)$, $g \in C(Y, Z)$, $h \in C(Z, W)$ we have $h(gf) = (hg)f$.

Diagrammatically, we think of categories as a bunch of points (objects) with arrows between them (morphisms). We use $\text{Mor}(C)$ or just C to denote the disjoint union of all hom-sets, and for $f \in C$ say $\text{dom } f = X$ and $\text{cod } f = Y$ iff $f \in C(X, Y)$. When the category being discussed is clear, we write $f : X \rightarrow Y$. Note that objects can be identified with their identity morphisms, so we often regard $\text{Ob}(C)$ as a subclass of $\text{Mor}(C)$, a perspective we call **objects as identities**.

Morphisms are classified as follows, with a summary given in fig. 1.2:

- A **monomorphism** $m : X \rightarrow Y$ is *left cancellable*, i.e. $mf = mg \iff f = g$. The monomorphism m is said to **split** iff it has a (not necessarily unique) left inverse or **retraction** $r : Y \rightarrow X$ such that $rm = 1_X$.

¹ Mac Lane, *Categories for the Working Mathematician*; Richter, *From Categories to Homotopy Theory*; Aluffi, *Algebra*; Awodey, *Category Theory*.

² Loosely speaking, a **class** is a collection which might be bigger than a set. For example, there exists a *universal class* V of all sets. In material set-theoretic foundations like von Neumann-Bernays-Gödel set theory (NBG) these are first-order objects in their own right, while Zermelo-Fraenkel set theory with Choice (ZFC) allows indirect treatment of classes as predicates. Yet another approach, taken by Tarski-Grothendieck set theory (TG), is to establish the existence of *universes*, which are sets "large enough to do all of mathematics in."

³ In more general settings, the morphisms between two objects are allowed to form a proper class. In this work, hom-sets will always be sets, meaning the categories discussed are always **locally small**.

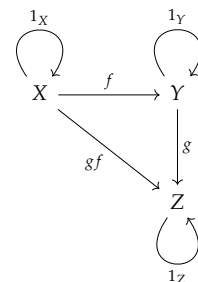

Figure 1.1: A schematic representation of a very simple category.

- An **epimorphism** is *right cancellable*, i.e. $fe = ge \iff f = g$. The epimorphism e is said to **split** iff it has a (not necessarily unique) right inverse or **section** $s : Y \rightarrow X$ such that $es = 1_Y$.
- An **isomorphism** has a (necessarily unique) two-sided inverse.
- An **endomorphism** has the same domain and codomain. The monoid of endomorphisms of an object is denoted $\text{End}_{\mathcal{C}}(X)$.⁴
- An **automorphism** is both an isomorphism and endomorphism. The group of automorphisms of an object is denoted $\text{Aut}_{\mathcal{C}}(X)$.

The following examples should give an impression of the prevalence of categories across different areas of mathematics:

Example 1.1. The category of sets Set is defined so that $X \in \text{Ob}(\text{Set})$ iff X is a set, and $f \in \text{Set}(X, Y)$ iff $f : X \rightarrow Y$ is a function. The category of finite sets FinSet is defined analogously but only includes finite sets. In both categories, we note that the notions injective function, monomorphism, and split monomorphism coincide; the notions surjective function, epimorphism, and split epimorphism coincide; and bijective function and isomorphism coincide.⁵

Example 1.2. The category of \mathbb{K} -vector spaces $\text{Vect}_{\mathbb{K}}$ is defined so that $V \in \text{Ob}(\text{Vect}_{\mathbb{K}})$ iff V is a \mathbb{K} -vector space, and $f \in \text{Vect}_{\mathbb{K}}(V, W)$ iff $f : V \rightarrow W$ is a \mathbb{K} -linear map. The category $\text{Vect}_{(\mathbb{K})}$ is defined analogously but only includes finite-dimensional vector spaces.

Example 1.3. The category of groups Grp is defined so that $G \in \text{Ob}(\text{Grp})$ iff G is a group, and $f \in \text{Grp}(G, H)$ iff $f : G \rightarrow H$ is a group homomorphism. The category FinGrp is defined analogously but only includes finite groups. Similarly, the category Ab contains only abelian groups.

Example 1.4. The category of rings Ring is defined so that $R \in \text{Ob}(\text{Ring})$ iff R is a ring, and $f \in \text{Ring}(R, T)$ iff $f : R \rightarrow T$ is a ring homomorphism.⁶

Example 1.5. The category of topological spaces Top is defined so that $X \in \text{Ob}(\text{Top})$ iff X is a topological space, and $f \in \text{Top}(X, Y)$ iff $f : X \rightarrow Y$ is a continuous function.

Examples 1.1 to 1.5 are very typical examples in that the objects are all some kind of *structured set* and the morphisms are the appropriate notion on *homomorphism*, i.e. structure-preserving maps.⁷ These are not the only kinds of categories:

Example 1.6. The empty category $\underline{0}$ has no objects and no morphisms.

Example 1.7. The trivial category $\underline{1}$ consists of a single object 0 , and a single morphism 1_0 .

A category for which all isomorphisms are automorphisms is called **skeletal**.

⁴ A **monoid** is a group with the requirement of inverse existence relaxed. That is, a monoid is a set with some associative binary operation and a (provably unique) identity element. The endomorphisms of an object form such a structure.

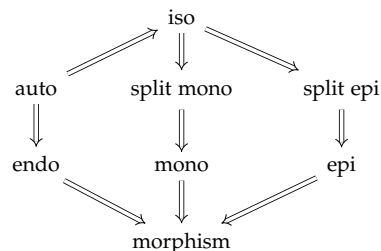

Figure 1.2: Relationship between different kinds of morphism in a category.

⁵ The implication epimorphism \implies split epimorphism in Set is equivalent to the Axiom of Choice (AC), and bijective \implies isomorphism also relies on this. A category in which all epimorphisms split is said to satisfy the **Internal Axiom of Choice**.

⁶ In this work rings and their homomorphisms are always unital, opting instead to use the terms **rng** the weaker non-unital notion. We do not assume commutativity for either.

⁷ Such categories are called **concrete**.

Example 1.8. Let G be a group.⁸ Then we may view G as a **group-as-category** \underline{G} consisting of a single object $\text{Ob}(\underline{G}) = \{\bullet\}$ such that $\underline{G}(\bullet, \bullet) = G$ and composition is given by multiplication in G .

A **subcategory** D of C is a category such that $\text{Ob}(D) \subseteq \text{Ob}(C)$ and $D(X, Y) \subseteq C(X, Y)$ for all $X, Y \in \text{Ob}(D)$. Then D is called a **full subcategory** iff in addition $D(X, Y) = C(X, Y)$ for all $X, Y \in D$. Hence examples 1.1 to 1.5 are subcategories of Set , while FinSet , $\text{Vect}_{(\mathbb{K})}$, FinGrp , and Ab are full subcategories of Set , $\text{Vect}_{\mathbb{K}}$, Grp , and Grp respectively. Moreover, Ring is a subcategory of Ab .

The **product** of two categories $C \times D$ has ordered pairs of objects and morphisms from C and D as its objects and morphisms, as depicted in fig. 1.3. This generalizes easily to finitary products. The **coproduct** $C \amalg D$ is just the disjoint union of its constituents.

1.1.2 Functors

Category theory is naturally married to a *structuralist* philosophy of mathematics, in that it is preoccupied with the relationships between objects — the morphisms. It is unsurprising then that homomorphisms of categories should play an important role.

Definition 1.9. A **functor** $F : C \rightarrow D$ between categories C, D maps every object $X \in C$ to an object $FX \in D$, and every morphism $f \in C(X, Y)$ a morphism $Ff \in C(FX, FY)$, such that

1. $(Fg)(Ff) = F(gf)$ for any $X, Y, Z \in C$, $f \in C(X, Y)$, and $g \in C(Y, Z)$;
2. $F1_X = 1_{FX}$ for any $X \in C$.

Clearly every category C possesses an **identity functor** denoted 1_C or just 1 , whose mappings on both objects and hom-sets are the identity map. Also, the objects of a category C are in correspondence with the *constant* functors $\underline{1} \rightarrow C$, a perspective we sometimes refer to as **objects as functors**.

Example 1.10. Regarding groups X, Y as categories as in example 1.8, a functor $\underline{f} : \underline{X} \rightarrow \underline{Y}$ is precisely a group homomorphism.

A functor is called **full** iff it is surjective on hom-sets, **faithful** iff it is injective on hom-sets, and **fully faithful** iff it is both.⁹ Thus the inclusion of a subcategory into a larger category is a faithful functor, while the inclusion of a full subcategory is a fully faithful functor. These are examples of **forgetful functors**, since they “forget” the property distinguishing objects of the subcategory from the larger category.

Before we introduce a more interesting example of a functor, note every category C has an associated **opposite category** C^{op} given by reversing all its morphisms, i.e. $C^{\text{op}}(X, Y) = C(Y, X)$.¹⁰ The term *contravariant functor* is sometimes used to refer to a mapping $F : C \rightarrow D$ which is like an ordinary, or *covariant*, functor, except in that it reverses composition order, so $F(gf) = (Ff)(Fg)$.

⁸ Or more generally, a monoid.

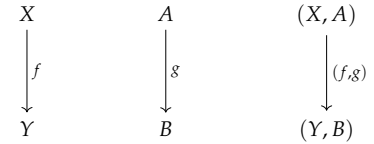

Figure 1.3: Morphisms in C, D , and $C \times D$.

⁹ To say that $F : C \rightarrow D$ is injective or surjective on hom-sets means that the restriction $F \upharpoonright C(X, Y) : C(X, Y) \rightarrow D(FX, FY)$ is injective or surjective for any objects $X, Y \in C$.

¹⁰ While the opposite category’s composition should be backwards too, we will always use the composition of the original category.

But this is exactly the same as a covariant functor $F : C^{op} \rightarrow D$. In this work, functors will always be covariant, and contravariant functors are defined by invoking the opposite category.

Example 1.11. Recall that the *dual* V^* of a vector space V is the space of all linear functionals on V , i.e. $V^* = \text{Vect}_{\mathbb{K}}(V, \mathbb{K})$. Given a \mathbb{K} -linear map $T \in \text{Vect}_{\mathbb{K}}(V, W)$, there is a corresponding dual map $T^* \in \text{Vect}_{\mathbb{K}}(W^*, V^*)$ defined by $(T^*f)v = f(Tv)$ for $f \in W^*$ and $v \in V$. It can be shown that $?^* : \text{Vect}_{\mathbb{K}}^{op} \rightarrow \text{Vect}_{\mathbb{K}}$ is a functor.

One is inclined to define a *category of categories* with functors as morphisms, though one must proceed carefully to avoid category theoretic analogues of Russel’s paradox.¹¹ We can at the very least construct a category of *small* categories Cat , a small category being one with a set of objects. Examples 1.8 and 1.10 imply Grp is a full subcategory of Cat .

We use similar language for functors as we do for morphisms: A functor with the same domain and codomain is called an **endofunctor**, while a functor with a two-sided inverse functor is called an **isofunctor** or **isomorphism of categories**.¹²

The product of categories allows the definition of a **bifunctor**, or more generally, a **multifunctor**, as a functor from a product category. Multifunctoriality is (strictly)¹³ stronger than functoriality in each argument: In fact, if $F : C \times D \rightarrow E$ is a mapping functorial in each argument, namely $F(C, -)$ and $F(-, D)$ are functors for any $C \in C$ and $D \in D$, then F is a bifunctor iff

$$\begin{array}{ccc}
 C & \xrightarrow{c} & C' \\
 \\
 \begin{array}{ccc}
 D & & F(C, D) \xrightarrow{F(c', D)} F(C', D) \\
 \downarrow d & & \downarrow F(C, d) \quad \searrow F(c, d) \quad \downarrow F(C', d) \\
 D' & & F(C, D') \xrightarrow{F(c, D')} F(C', D')
 \end{array} & & (1.1)
 \end{array}$$

commutes for any $c \in C(C, C')$ and $d \in D(D, D')$.¹⁴

Another important multifunctor is the *hom-functor*:

Definition 1.12. Let C be a category. The **hom-functor** $\text{hom}_C : C^{op} \times C \rightarrow \text{Set}$, also denoted C , is defined so that it maps pairs of objects to the corresponding hom-set. For $C \in C$ and a morphism $f \in C(A, B)$ we have

$$\begin{aligned}
 f_* &:= C(C, f) : C(C, A) \rightarrow C(C, B) \\
 &g \mapsto fg \\
 f^* &:= C(f, C) : C(B, C) \rightarrow C(A, C) \\
 &g \mapsto gf.
 \end{aligned}$$

The functions f_* and f^* are sometimes called the **pushforward** and **pullback** respectively.

¹¹ One of the primary advantages of TG as a material set-theoretic foundation for category theory is that one can always construct a “sufficiently large” category of categories, by considering all categories that are small relative to some universe. Since a universe cannot contain itself, this circumvents Russel’s paradox. For a discussion of category theoretic analogues to Russel’s paradox, see Simpson FOM.

¹² As we will see, isomorphism of categories turns out to be stronger than what we need in most cases, a better notion being *equivalence of categories*.

¹³ For a counterexample, let $\underline{G}, \underline{H}$ be groups-as-categories. A bifunctor $F : \underline{G} \times \underline{H} \rightarrow C$ is a group action of $G \times H$ on an object $F \bullet \in C$, while functoriality in each argument separately gives an action of the free product $G \amalg H$.

¹⁴ In order to make sense of notation like $F(C, d)$ in eq. (1.1) one must regard objects as identities.

1.1.3 Natural transformations

It may be surprising that one can take the categorical inclination towards morphisms one step further, and consider *morphisms between functors*.¹⁵

Definition 1.13. Let C, D be categories and $F, G : C \rightarrow D$ be functors. A **natural transformation** $\eta : F \Rightarrow G : C \rightarrow D$ is a family of morphisms $(\eta_X)_{X \in C}$ in D , called its *components*,¹⁶ so that for $f \in C(X, Y)$

$$\begin{array}{ccccc}
 X & & FX & \xrightarrow{\eta_X} & GX & & F \\
 \downarrow f & & \downarrow Ff & & \downarrow Gf & & \downarrow \eta \\
 Y & & FY & \xrightarrow{\eta_Y} & GY & & G
 \end{array} \quad (1.2)$$

commutes.¹⁷

Given categories C, D , the **functor category** D^C has functors from C to D as objects and natural transformations between these functors as morphisms. An isomorphism in D^C is called a **natural isomorphism** or **natural equivalence**, and we write $F \simeq G$ if there exists a natural isomorphism between functors F and G .

One of the miracles of category theory is that this notion of *natural* often formalizes what one might call the *psychological* notion of naturality, as seen in the following proposition:¹⁸

Proposition 1.14. *Finite dimensional vector spaces are naturally isomorphic to the duals of their duals, i.e. there exists a natural isomorphism*

$$\eta : 1 \Rightarrow (?^*)^* : \text{Vect}_{(\mathbb{K})} \rightarrow \text{Vect}_{(\mathbb{K})}.$$

Proof. The components of η are

$$\begin{aligned}
 \eta_V : V &\rightarrow (V^*)^* = \text{Vect}_{(\mathbb{K})}(V^*, \mathbb{K}) \\
 v &\mapsto (f \mapsto fv)
 \end{aligned}$$

where $\ker \eta_V = 0$, thus there exist inverses η_V^{-1} forming components of η_V . Letting $T \in \text{Vect}_{(\mathbb{K})}(V, W)$, we see that for $v \in V$ and $f \in W^*$ we have

$$\begin{aligned}
 ((T^*)^* \eta_V v) f &= ((T^*)^*(g \mapsto gv)) f = (g \mapsto gv)(T^* f) \\
 &= (T^* f) v = fTv(g \mapsto gTv) f = (\eta_W Tv) f
 \end{aligned}$$

so

$$\begin{array}{ccc}
 V & \xrightleftharpoons{\eta_V} & (V^*)^* \\
 \downarrow T & & \downarrow (T^*)^* \\
 W & \xrightleftharpoons{\eta_W} & (W^*)^*
 \end{array} \quad (1.3)$$

commutes.¹⁹

¹⁵ The idea of morphisms between morphisms may not be surprising to those familiar with homotopy theory.

¹⁶ We use the notation $F \Rightarrow G$ instead of $F \rightarrow G$ to emphasize that these are a second level of morphisms — morphisms between morphisms.

¹⁷ Commutative diagrams like eq. (1.2) appear everywhere there are categories, and this work is no exception. Each node represents an object in some category, and arrows between them represent morphisms between these objects. To say the diagram commutes means any path along arrows with the same start and end points give equal composition of morphisms, i.e. in this case $(Gf)\eta_X = \eta_Y(Ff)$.

¹⁸ Formalizing proposition 1.14 was presented as the motivation for introducing the notions of category theory in its originating paper, Eilenberg and Mac Lane, “General Theory of Natural Equivalences.”

□

¹⁹ We neglect to label inverse morphisms in commutative diagrams like eq. (1.3) when inverse-status follows from commutativity.

In some situations, we will come across two categories which are *essentially* the same, but fall short of being isomorphic. A (natural) **equivalence** of categories C, D is a pair $F : C \rightleftarrows D : G$ of functors such that²⁰

$$GF \simeq 1_C \quad \text{and} \quad FG \simeq 1_D$$

whence we write $C \simeq D$ and say G is an essential inverse of F and vice versa. Equivalence of categories forms an equivalence relation weaker than isomorphism of categories.

Often it is the isomorphism classes within a category that are important,²¹ and different objects in the same isomorphism class can be treated as if they were the same. A **skeleton** $\text{Sk}(C)$ of a category C is what we get when we collapse all isomorphism classes to individual objects, or what amounts to the same, form a full subcategory with exactly one representative of each isomorphism class.²² Clearly a skeleton category is skeletal.

Example 1.15. Isomorphism classes in $\text{Vect}_{\mathbb{K}}$ correspond to dimensions, and the canonical representative of dimension α is $\mathbb{K}^{(\alpha)}$. Restricting to $\text{Vect}_{(\mathbb{K})}$, we see that its skeleta are isomorphic to $\text{Mat}_{\mathbb{K}}$, the algebra of matrices over \mathbb{K} .

Lemma 1.16. *Skeletal categories C, D are equivalent iff they are isomorphic.*

Proof. Suppose $F : C \rightleftarrows D : G$ defines an equivalence of categories. Then there exist natural isomorphisms $\eta : 1 \Rightarrow FG : C \rightarrow C$ and $\epsilon : 1 \Rightarrow FG : D \rightarrow D$, which must be identities since C and D are skeletal. □

Proposition 1.17. *Two categories C, D are equivalent iff they have isomorphic skeleta, i.e. $C \simeq D$ iff $\text{Sk}(C) \cong \text{Sk}(D)$.*

Proof. It suffices to show every category is equivalent to its skeleton, since the full result follows from lemma 1.16 and transitivity of equivalence. Let $I : \text{Sk}(C) \hookrightarrow C$ be the inclusion functor. We construct a functor $F : C \rightarrow \text{Sk}(C)$ which maps objects to their unique isomorphic representative. For any $Y \in C$ invoke AC to fix an isomorphism $\varphi_Y : Y \rightarrow FY$, and for a general $f : X \rightarrow Y$ define $Ff = \varphi_Y f \varphi_X^{-1}$. Then

$$\begin{array}{ccc}
 X & \begin{array}{c} \xrightarrow{\varphi_X} \\ \xleftarrow{\varphi_X^{-1}} \end{array} & FX \\
 \downarrow f & & \downarrow Ff \\
 Y & \begin{array}{c} \xrightarrow{\varphi_Y} \\ \xleftarrow{\varphi_Y^{-1}} \end{array} & FY
 \end{array}$$

commutes whence $\varphi : 1 \Rightarrow IF : C \rightarrow C$ is a natural isomorphism. Therefore $IF \simeq 1_C$ and $FI = 1_D$. □

²⁰ i.e. $F : C \rightarrow D$ and $G : D \rightarrow C$.

²¹ An isomorphism class is an equivalence class (which may be a proper class) of all objects isomorphic to some object.

²² Guaranteeing the existence of skeleta for arbitrary categories requires AC, as does proposition 1.17. See Richter, *From Categories to Homotopy Theory*, proposition 2.6.4, p. 48.

1.1.4 Adjunction

So-called universal properties are most naturally expressed in category theoretic language, and are the primary method for constructing functors. The idea is to find some property of morphisms which uniquely characterizes an object in a category up to *unique* isomorphism. An object characterized thus is called a **universal construction**, and their explicit constructions serve as existence proofs but can otherwise be disregarded.²³

A particularly pertinent recipe for universal constructions is the *adjunction*. While adjunction was discovered some time after the original triad of concepts of categories, functors, and natural transformation, first being described by Kan,²⁴ it is now rightfully considered one of the fundamental concepts of category theory. As such, “everything is an adjoint” has become an oft-cited aphorism of the subject.

In many situations in mathematics, we find two very different kinds of mathematical objects (i.e. in nonequivalent categories) whose homomorphisms are nonetheless in a special kind of correspondence.

Definition 1.18. Given a pair of functors $F : D \rightleftarrows C : U$, an **adjunction** is a natural isomorphism

$$\begin{aligned} \text{hom}_D(F \times 1_D) &\cong \text{hom}_C(1_C \times U) \\ \varphi_{C,D} : D(FC, D) &\rightleftarrows C(C, UD) : \varphi_{C,D}^{-1} \end{aligned}$$

We thence write $F \dashv U$, call U the **right adjoint** of F , and for $f \in D(FC, D)$ call $f^\flat = \varphi_{C,D}(f)$ the **right adjunct** of f . Similarly, we call F the **left adjoint** of U and call $g^\sharp = \varphi_{C,D}(g)$ the **left adjunct** of $g \in D(C, UD)$.

This definition is perhaps the most technical introduced thus far, but should become more transparent with an example. In most cases, we think of U as a *forgetful functor* and F as a *free functor*, together forming a *free-forgetful adjunction*.

Example 1.19. Let S be a set. The **free group** FS is a group consisting of all finite words (i.e. formal strings) written in the alphabet $S \amalg S^{-1}$ including the empty word such that no element $s \in S$ appears next to its inverse s^{-1} . The group operation is given by concatenation of words, where at any point ss^{-1} or $s^{-1}s$ is deleted.²⁵

Now there also exists an injection $\iota_S \in \text{Set}(S, FS)$, and we see that F admits a unique extension to a functor such that $\iota : 1 \Rightarrow F : \text{Set} \rightarrow \text{Set}$ is a natural transformation.

Now if S is a set and G is a group, specifying a function $f \in \text{Set}(S, G)$ is the same as specifying the *adjunct* group homomorphism $g \in \text{Grp}(FS, G)$. Thus F is the left adjoint of the forgetful inclusion $\text{Grp} \hookrightarrow \text{Set}$.

Proposition 1.20. Let $F : D \rightleftarrows C : U$ be a pair of functors. The following are equivalent:

²³ This is one of two ways of dealing with universal constructions. The other is to take an explicit construction as a definition, and take the corresponding universal property as a theorem.

²⁴ Kan, “Adjoint Functors.”

²⁵ Thus, FS is the “most general” or “freest” group containing S , where two words are considered equal iff they must be by the axioms of a group.

1. $F \dashv U : D \rightarrow U$ form an adjunction in the sense of definition 1.18.
2. There exists a natural transformation $\eta : 1 \Rightarrow UF : C \rightarrow C$, called the **unit of adjunction** such that for any objects $C \in C, D \in D$, and morphism $f \in C(C, UD)$, there exists a unique **adjunct** $f^\sharp \in D(FC, D)$ such that $f = (Uf^\sharp)\eta_C$, as shown in fig. 1.4.
3. There exists a natural transformation $\epsilon : FU \Rightarrow 1 : C \rightarrow C$ called the **coünit** of adjunction such that for any objects $C \in C, D \in D$, and morphism $g \in D(FC, D)$, there exists a unique **adjunct** $g^\sharp \in C(C, UD)$ such that $g = \epsilon_D(Fg^\sharp)$, as shown in fig. 1.5.

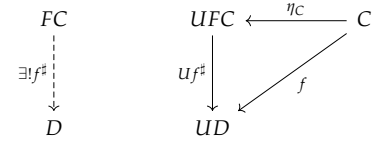

Figure 1.4: Universal property of the unit of adjunction

Proof (sketch). As suggested by our notation, the conditions are related by

$$\begin{aligned} \eta_C &= \varphi_{C,FC}(1_{FC}) & \varphi^{-1}(f) &= f^\sharp \\ \epsilon_D &= \varphi_{UD,D}^{-1}(1_{UD}) & \varphi(g) &= f^\flat. \end{aligned}$$

That these define isomorphisms follows from the universal properties of the unit and coünit, and naturality follows from naturality of the unit and coünit. For the details see Awodey.²⁶ \square

Corollary 1.21. *Every equivalence of categories forms an adjunction.*

Proving the following would demand a detour to the *Yoneda lemma*, we refer the reader to Awodey.²⁷

Proposition 1.22. *Let $F : C \rightarrow D$ be a functor. The left or right adjoint of F , if it exists, is unique up to unique natural isomorphism.*

A PARTICULAR CLASS of adjoints crops up in many categories. Let C^n denote the product of C with itself n -times.²⁸ We let $\Delta_n : C \rightarrow C^n$ denote the **diagonal functor** taking $f \in C$ to $(f, \dots, f) \in C^n$. When they exist, the functors (\amalg_n) and (\prod_n) in the chain

$$(\amalg_n) \dashv \Delta_n \dashv (\prod_n) \tag{1.4}$$

are called the n -ary (categorical) **coproduct** and **product** respectively. In particular the 0-ary coproduct and product are objects-as-functors which we call the **terminal** and **initial** object respectively.²⁹

The reader may enjoy unwrapping eq. (1.4) in terms of units or coümits of adjunction. Consider the binary case. The unit of the former adjunction is typically denoted

$$\begin{aligned} \iota_{X_1, X_2} &= (\iota_1, \iota_2) : (X_1, X_2) \rightarrow (X_1 \amalg B, A \amalg X_2) \\ \iota_i &: X_i \rightarrow X_1 \times X_2 \end{aligned}$$

and called a **natural inclusion**. For $f : X_1 \rightarrow Z$ and $g : X_2 \rightarrow Z$, we write the adjunct as $\{f, g\} := (f, g)^\sharp : X_1 \amalg X_2 \rightarrow Z$. The universal property is shown in fig. 1.6.

On the other hand, the coünit of the latter adjunction is typically denoted

$$\begin{aligned} \pi_{X_1, X_2} &= (\pi_1, \pi_2) : (X_1 \times X_2, X_1 \times X_2) \rightarrow (X_1, X_2) \\ \pi_i &: X_1 \times X_2 \rightarrow X_i \end{aligned}$$

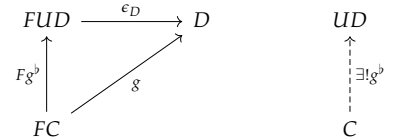

Figure 1.5: Universal property of the coünit of adjunction

²⁶ Awodey, *Category Theory*, §9.2, pp. 211–15.

²⁷ Awodey, proposition 9.8, p. 217.

²⁸ This is isomorphic to the functor category $C^{[n]}$ where $[n] := \coprod_{i=1}^n 1$. In particular, $C^0 = \underline{0}$.

²⁹ We use the infix operators (\amalg) and (\times) for the product and coproduct respectively.

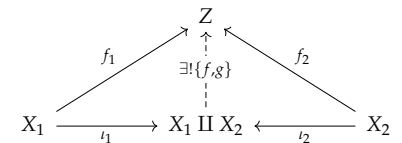

Figure 1.6: Universal property of the binary coproduct

and called a **natural projection**. For $f : Z \rightarrow X_1$ and $g : Z \rightarrow X_2$, we write the adjunct as $(f, g) := (f, g)^b : Z \rightarrow X_1 \times X_2$.³⁰ The universal property is shown in fig. 1.7.

As the names suggest, the terminal object T has a unique morphism $X \rightarrow T$ from every object X , while the initial object I has a unique morphism $I \rightarrow Z$ to every object Z .

Examples of coproducts and products will be familiar in many categories.

Example 1.23. In Set , the terminal object is any singleton, the initial object is the empty set, the product is the cartesian product, and the coproduct is the disjoint union.

Example 1.24. In Grp , the initial and terminal objects are the trivial group, the product is the usual product of groups, and the coproduct is the free product of groups.

Example 1.25. In Ring , the initial object is \mathbb{Z} , the terminal object is 0 , the product is the usual product of rings, and the coproduct is the free product of rings.³¹

Example 1.26. In Ab and $\text{Vect}_{\mathbb{K}}$, finitary products and coproducts agree and are given by the direct sum. In particular, both the initial and terminal object is 0 .³²

Example 1.27. In Cat , the terminal object is $\underline{1}$, the initial object is $\underline{0}$, the product is the product category, and the coproduct is the coproduct category.

1.2 Linear algebra

We now review some definitions and results from linear algebra, taking the opportunity to establish notation.

1.2.1 Vector spaces and modules

The module plays a fundamental role in this work. Recall a \mathbb{K} -vector space is an abelian group under addition equipped with an appropriate action from a field \mathbb{K} . It is straightforward to generalize this definition to an arbitrary ring R of scalars. A (left)³³ **R -module** V is an abelian group under addition with a left R -action, called **scaling**, so that for $v, w \in V$ and $r, t \in R$,

$$\begin{aligned} 1v &= v, & (rt)v &= r(tv), \\ r(u+v) &= ru + rv, & (r+t)u &= ru + tu. \end{aligned}$$

Note a ring R is itself an R -module under left multiplication, which we call the **regular R -module**.

Let V and W be R -modules. An **R -morphism** or R -linear map $f : V \rightarrow W$ is a homomorphism of the underlying abelian groups that respects scaling, so

$$f(ru + tv) = rf u + tf v.$$

³⁰ It should be clear from context whether (f, g) is meant this way or as an element of C^2 .

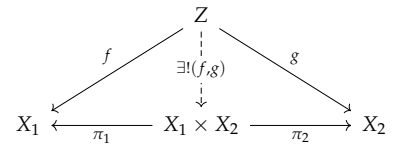

Figure 1.7: The universal property of the product

³¹ This lesser known “free product” is constructed similarly to the free product of groups. We will not use the coproduct of rings in this work.

³² In fact, both Ab and $\text{Vect}_{\mathbb{K}}$ are examples of *abelian categories*, which are discussed in §A.

³³ It is of course possible to define right modules, and these notions need not coincide for noncommutative R . Unless otherwise stated, all modules in this work are left modules.

It is not difficult to show that R -modules and their morphisms form a category ${}_R\text{Mod}$. In the case of a field \mathbb{K} , the category ${}_{\mathbb{K}}\text{Mod}$ is identical to $\text{Vect}_{\mathbb{K}}$.

An R -**submodule** S of V is an additive subgroup closed under scaling, i.e. $RS \subseteq S$. Examples of R -submodules include the image and kernel of an R -morphism $f : V \rightarrow W$, given by

$$\ker f = \{v \in V : f(v) = 0\}, \quad \text{im } f = \{f(v) : v \in V\}.$$

respectively.³⁴

Since modules feature extensively in this work, we find it convenient in certain contexts to use the ground ring R as an abbreviation for the corresponding category ${}_R\text{Mod}$. For example we write $\text{End}_R(X)$ for $\text{End}_{{}_R\text{Mod}}(X)$, and $X \cong_R Y$ for “ X and Y are isomorphic as R -modules.” Of course this notation works for vector spaces too. When dealing with *subobjects* in a general concrete category \mathcal{C} ,³⁵ we write $X \leq_{\mathcal{C}} Y$ for “ X is a subobject of Y in \mathcal{C} ,” or when the meaning is clear, just $X \leq Y$. For submodules, we write $S \leq_R V$.

Given $S \leq_R V$, the **quotient module** V/S is the corresponding quotient abelian group equipped with the R -action defined by $r(v + S) = rv + S$. The R -epimorphism $\pi : V \twoheadrightarrow V/S : v \mapsto v + S$ is called the **canonical projection**.

Proposition 1.28. *Let $f : V \rightarrow W$ be an R -morphism, and $S \leq_R V$ be such that $\ker f \leq_R S$. Then there exists a unique R -morphism $\bar{f} : V/S \rightarrow W$ so that $f = \bar{f}\pi$, as shown in fig. 1.8.*

Proof. An R -morphism $f : V \rightarrow W$ can be factored as $\bar{f}\pi$ iff $f(v + S) = \{f(v)\}$ for all $v \in V$, and this holds iff $\pi(S) = 0$, i.e. $S \leq_R \ker f$. The uniqueness follows from π being an epimorphism. \square

Corollary 1.29. *Let $f : V \rightarrow W$ be an R -morphism. Then $V/\ker f \cong_R \text{im } f$.*

Proof. One can show that $\bar{f} : V \twoheadrightarrow \text{im } f$ has the same property as $\pi : V \twoheadrightarrow V/\ker f$ in proposition 1.28. It follows by the uniqueness of morphisms in the commutative diagram in fig. 1.9 that $\text{im } f$ and $V/\ker f$ are canonically isomorphic. \square

THE RELAXATION OF SCALARS to a general ring in the definition of a module has far-reaching consequences, and modules are capable of behaviour completely alien to vector spaces. One such behaviour is the existence of *torsion*: Elements which yield zero when multiplied by some nonzero scalar. Just how general modules can be is demonstrated by the following proposition:

Proposition 1.30. *The categories ${}_{\mathbb{Z}}\text{Mod}$ and Ab are identical.³⁶*

Proof. Every \mathbb{Z} -module is an abelian group, and every \mathbb{Z} -module homomorphism is a homomorphism of abelian groups. At the same time, every abelian group A admits a \mathbb{Z} -action uniquely specified by the condition that $1x = x$ for all $x \in A$, which is also preserved by group homomorphisms. \square

³⁴ That these are R -submodules follows directly from the R -linearity of f .

³⁵ Subobjects have a rigorous category theoretic definition, but we will just appeal to whatever the usual definition is in the appropriate category, e.g. subgroup, subring, subspace, &c.

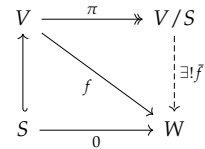

Figure 1.8: Universal property of the quotient R -module V/S .

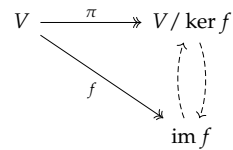

Figure 1.9: The first isomorphism theorem via the universal property of the quotient module

³⁶ In particular, we have an isofunctor ${}_{\mathbb{Z}}\text{Mod} \cong \text{Ab}$. This is related to \mathbb{Z} being initial in Ring .

Another departure from the behaviour of vector spaces lies in the fact that not every R -module has a basis, even with AC.³⁷ Such modules are rather special and are known as **free modules**, since they are given by the adjoint of the forgetful functor ${}_R\text{Mod} \hookrightarrow \text{Set}$: For a given set we may construct the free module $R^{(S)}$ as maps of finite support from S to R .³⁸ If S is finite, then $R^S = R^{(S)}$.

An R -module is said to be **finitely generated** iff it spanned by a finite set of elements, or equivalently, it is isomorphic to a quotient of R^n for some $n \in \mathbb{N}_0$.³⁹ We denote the full subcategory of ${}_R\text{Mod}$ acquired by restricting to finitely generated R -modules by $(R)\text{Mod}$, and use our same convention of occasionally denoting this category (R) .

The only \mathbb{K} -vector spaces without \mathbb{K} -vector subspaces are those isomorphic to \mathbb{K} itself. For general R -modules this is not the case. An R -module is called **simple** iff its only proper R -submodule is the zero module.

Example 1.31. Let $\mathbb{Z}_p^+ := (\mathbb{Z}/p\mathbb{Z})^+$ be the cyclic group of prime order p . Then \mathbb{Z}_p^+ is simple as a \mathbb{Z} -module.

The following simple lemma is vastly applicable, as we shall see in §3.

Lemma 1.32 (Schur). *Let V, W be simple R -modules. Then every nonzero R -morphism is an R -isomorphism. In particular, the endomorphism ring $\text{End}_R(V)$ of a simple module is a division ring.⁴⁰*

Proof. Since $\ker f \leq_R V$ and $\text{im } f \leq_R W$ are submodules they must either be zero or equal V or W respectively. If $f \neq 0$ then $\ker f \neq V$ and $\text{im } f \neq 0$, whence f is an epimorphism and monomorphism and therefore must be an R -isomorphism. \square

1.2.2 \mathcal{K} -multilinearity and \mathcal{K} -tensor products

The familiar notion of multilinearity extends to \mathcal{K} -modules when \mathcal{K} is a commutative ring. For modules V_1, \dots, V_n, W a function $f : V_1 \times \dots \times V_n \rightarrow W$ is called **\mathcal{K} -multilinear** iff it is a \mathcal{K} -linear in each argument separately. In particular, if $f : V_1 \times V_2 \rightarrow W$ is \mathcal{K} -bilinear then

$$\begin{aligned} f(ra + tb, c) &= rf(a, c) + tf(b, c) \\ f(a, rc + tc) &= rf(a, c) + tf(a, d) \end{aligned}$$

for any $a, b \in V_1, c, d \in V_2$, and $r, t \in \mathcal{K}$.

The **\mathcal{K} -tensor product** $V_1 \otimes_{\mathcal{K}} V_2$ is a \mathcal{K} -module so that \mathcal{K} -bilinear maps $V_1 \times V_2 \rightarrow W$ are in natural bijection with \mathcal{K} -linear maps $V_1 \otimes_{\mathcal{K}} V_2 \rightarrow W$. Or rather, the tensor product is a pair consisting of a \mathcal{K} -module $V_1 \otimes_{\mathcal{K}} V_2$ and a \mathcal{K} -bilinear map $(\otimes) : V_1 \times V_2 \rightarrow V_1 \otimes_{\mathcal{K}} V_2$ such that any \mathcal{K} -bilinear map $f : V_1 \times V_2 \rightarrow W$ factors through (\otimes) with a unique \mathcal{K} -linear map $\bar{f} : V_1 \otimes_{\mathcal{K}} V_2 \rightarrow W$ so that the diagram in fig. 1.10 commutes. It follows that such a pair $(V_1 \otimes_{\mathcal{K}} V_2, \otimes)$, if it exists, is unique up to unique isomorphism.

³⁷ Here basis refers to an R -linearly independent spanning set, so that every element of the module has a unique representation as a linear combination of basis elements.

³⁸ A function $f : S \rightarrow R$ has **finite support** iff $f(x) = 0$ for all but finitely many $x \in S$.

³⁹ Let S be a finite set spanning an R -module V . The linear map $\varphi : R^{(S)} \rightarrow V$ defined by $s \mapsto s$ for $s \in S$ is an epimorphism, and by corollary 1.29 $V \cong_R R^{(S)} / \ker \varphi$. We also have $R^{(S)} \cong R^{|S|}$.

⁴⁰ A **division ring** is a nontrivial ring such that every nonzero element has a multiplicative inverse.

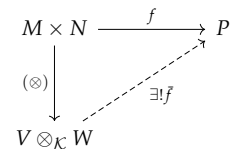

Figure 1.10: The universal property of the tensor product $V \otimes_{\mathcal{K}} W$.

Proposition 1.33. *The tensor product $V \otimes_{\mathcal{K}} W$ of \mathcal{K} -modules V, W exists.*

Proof. Let $\mathcal{K}^{(V \times W)}$ be the free module on the set $V \times W$ with the natural inclusion function $\iota : V \times W \hookrightarrow \mathcal{K}^{(V \times W)}$. Let S denote the \mathcal{K} -submodule spanned by elements of the form

$$\begin{aligned} &\iota(v_1, \alpha w_1 + \beta w_2) - \alpha \iota(v_1, w_1) + \beta \iota(v_1, w_2), \\ &\iota(\alpha v_1 + \beta v_2, w_1) - \alpha \iota(v_1, w_1) - \beta \iota(v_2, w_1) \end{aligned}$$

for $v_1, v_2 \in V, w_1, w_2 \in W$, and $\alpha, \beta \in \mathcal{K}$. We construct the tensor product as the quotient module

$$V \otimes_{\mathcal{K}} W := \mathcal{K}^{(V \times W)} / S$$

with its canonical projection $\pi : \mathcal{K}^{(V \times W)} \rightarrow V \otimes_{\mathcal{K}} W$, so that

$$(\otimes) = \pi \iota : V \times W \rightarrow V \otimes_{\mathcal{K}} W.$$

We need to show these data satisfy the universal property in fig. 1.10. By construction the map (\otimes) is \mathcal{K} -bilinear.

Let $f : V \times W \rightarrow Z$ be \mathcal{K} -bilinear. By the free-forgetful adjunction of the free module there exists a unique \mathcal{K} -linear map \tilde{f} so that the diagram in fig. 1.11 commutes, and by \mathcal{K} -bilinearity it follows that $S \leq_{\mathcal{K}} \ker \tilde{f}$, so by proposition 1.28 \tilde{f} factors uniquely through π , yielding the commutative diagram in fig. 1.12 as required. \square

Proposition 1.34. *Suppose $\{v^i\}_{i \in I}$ and $\{w^j\}_{j \in J}$ are bases for \mathcal{K} -modules V and W respectively.⁴¹ Then $\{v^i \otimes w^j\}_{(i,j) \in I \times J}$ is a basis for $V \otimes_{\mathcal{K}} W$.*

Proof. A \mathcal{K} -bilinear map $f : V \times W \rightarrow Z$ is determined by the images $f(v^i, w^j)$ of basis elements, which are free to take any value in Z . If there existed some $u \in V \otimes_{\mathcal{K}} W$ which was not a linear combination of the $v^i \otimes w^j$, then the image of $\tilde{f}(u) \in Z$ would not affect the composition $\tilde{f}(\otimes) : V \times W \rightarrow Z$, violating uniqueness. Similarly, the existence of a subset $S \subseteq I \times J$ such that $\sum_{(i,j) \in S} \lambda_{i,j} v^i \otimes w^j = 0$ for some coefficients $\lambda_{i,j} \in \mathcal{K}$ places a restriction on the values of $f(v_i, w_j)$ if this is to factor through (\otimes) , violating existence. \square

We will almost always talk about \mathcal{K} -linear maps $V \otimes_{\mathcal{K}} W \rightarrow Z$ instead of \mathcal{K} -bilinear maps $V \times W \rightarrow Z$. The same goes for multilinear maps, which can be viewed as \mathcal{K} -linear maps from higher iterated tensor products. In §2 we will explore a certain generalization of tensor products.

1.3 Quivers

The term “quiver”, a calque of the German *Köcher*, was first proposed by Peter Gabriel as an alternative to the already overloaded term “graph.”⁴² Using the concepts introduced thus far, quivers admit a particularly slick definition. The **walking quiver** is the category \mathbf{Q} whose objects are E, V for *edges* and *vertices* respectively, and

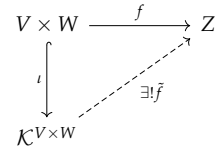

Figure 1.11: Universal property of the free module $\mathcal{K}^{(V \times W)}$.

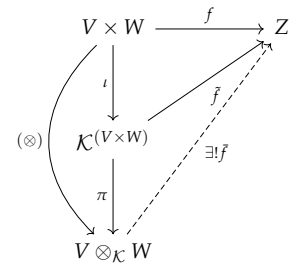

Figure 1.12: Constructing the universal morphism for the tensor product from a quotient of a free module.

⁴¹ The upper index should not be interpreted as an exponent.

⁴² Gabriel, “Unzerlegbare Darstellungen I.”

whose non-identity morphisms are $s, t : E \rightarrow V$ for *source* and *target* respectively. A **quiver** Γ is a functor $\Gamma : \mathbf{Q} \rightarrow \mathbf{Set}$, a **quiver homomorphism** is a natural transformation of quivers, and the category of quivers is the functor category $\mathbf{Set}^{\mathbf{Q}}$.

We picture a quiver Γ as a directed graph as in fig. 1.13 with labelled vertices ΓV and edges ΓE , with multiple edges allowed between the same source and target. It is already clear that the notation (Γs) and (Γt) can become unwieldy, so when the quiver in question is clear we simply write s and t . We will typically assume all quivers to be **finite**, meaning ΓV and ΓE are finite sets. The category of finite quivers is $\mathbf{FinSet}^{\mathbf{Q}}$. Given $x, y \in \Gamma V$, we define

$$\Gamma(x, y) = \{f \in \Gamma E : s(f) = x \wedge t(f) = y\}$$

and if $f \in \Gamma(x, y)$ we write $f : x \rightarrow y$. By **undirected edge** between $x, y \in \Gamma V$ we understand a pair of (distinct) edges $f, g \in \Gamma E$ such that $f : x \rightarrow y$ and $g : y \rightarrow x$. A quiver is thus called **undirected** iff all its edges arise from undirected edges.

We call the function $|\Gamma(-, -)| : \Gamma V \times \Gamma V \rightarrow \mathbb{N}_0$ the **adjacency matrix** of Γ , since if $\Gamma V = \{v_i\}_{i=1}^r$ this is represented by an $r \times r$ matrix A_{ij} . A quiver is therefore undirected iff A is symmetric and its diagonal entries are even.

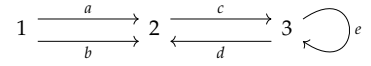

Figure 1.13: An example quiver Γ with $\Gamma V = \{1, 2, 3\}$, $\Gamma E = \{a, b, c, d, e\}$, $(\Gamma s)a = (\Gamma s)b = 1$, $(\Gamma t)a = (\Gamma t)b = 2$, $(\Gamma s)c = (\Gamma t)d = 2$, and $(\Gamma t)c = (\Gamma s)d = 3$, $(\Gamma s)e = (\Gamma t)e = 3$.

Extra structure on categories, and internalization

Many of the categories heretofore introduced exhibit structure beyond basic “vertical” composition of morphisms. For example, the category Set has products, but also *hom-objects*, and as we shall see these operations are adjoint.¹ A similar statement can be made about $\mathcal{K}\text{Mod}$, where rather than the categorical product it is the tensor product which is left adjoint to its internal hom-functor. In general, a category with a nice product-like bifunctor (often thought of as “horizontal composition”) is called *monoidal*, while internal hom-objects make a category *closed*. A very fruitful process in category theory is *internalization*, whereby one rephrases Bourbaki-style set theoretic definitions of constructions — such as monoids, rings, or even categories — in terms of objects and morphisms in Set , often taking advantage of monoidal or closed structure. These definitions may then be imported into other categories to yield new structures of independent use and interest.

In this chapter we develop the language of monoidal and closed categories, with an eye towards Set and $\mathcal{K}\text{Mod}$. We find it useful to introduce the graphical formalism of *string diagrams* due to their expressive power for simultaneously representing vertical and horizontal composition in monoidal categories. An attempt to internalize groups to arbitrary monoidal categories naturally leads us to the idea of a *Hopf monoid*, a structure whose ubiquity will become apparent in §3 and which play an important role in this thesis.

2.1 Monoidal categories and vertical categorification

Vertical categorification is a process lacking a single definition, but the idea is to translate some kind of algebraic structure on elements of a set into one on objects in a category.² In practice it usually pays to weaken the defining identities (equalities) of the original structure to natural isomorphisms in the vertical categorification. A simple example is the cartesian product on Set . Intuitively, this seems to exhibit monoid-like behaviour. While there is no strict unit, one easily verifies that any singleton behaves like a unit *up to isomorphism*, and a similar statement can be made about associativity and commutativity. This is made rigorous by the following definition:³

¹ In fact, the structure of Set is much richer, being that of a **topos**, an important concept in categorical logic and foundations of mathematics. We will not define topoi here.

² In particular, a small and discrete categorified gadget should be equivalent to an ordinary gadget.

³ Mac Lane, *Categories for the Working Mathematician*, §VII.1, pp. 161–163.

Definition 2.1. A category \mathcal{C} is **monoidal** iff it is equipped with

- a bifunctor $(\otimes) : \mathcal{C} \times \mathcal{C} \rightarrow \mathcal{C}$ called the **tensor product**;
- an object $\mathbb{1} \in \mathcal{C}$ called the **tensor unit**;
- a natural isomorphism with components $\alpha_{x,y,z} : (x \otimes y) \otimes z \rightarrow x \otimes (y \otimes z)$ in $\mathcal{C}^{\mathcal{C} \times \mathcal{C} \times \mathcal{C}}$ called the **associator**;
- natural isomorphisms $\lambda_x : \mathbb{1} \otimes x \rightarrow x$ and $\rho_x : x \otimes \mathbb{1} \rightarrow x$ in $\mathcal{C}^{\mathcal{C}}$ called the **left and right unitor** respectively;

satisfying the **triangle identity**

$$\begin{array}{ccc} (x \otimes \mathbb{1}) \otimes y & \xrightarrow{\alpha_{x,\mathbb{1},y}} & x \otimes (\mathbb{1} \otimes y) \\ & \searrow \rho_x \otimes 1_y & \swarrow 1_x \otimes \lambda_y \\ & x \otimes y & \end{array}$$

and the **pentagon identity**

$$\begin{array}{ccccc} & & (w \otimes x) \otimes (y \otimes z) & & \\ & \nearrow \alpha_{w \otimes x, y, z} & & \searrow \alpha_{w, x, y \otimes z} & \\ ((w \otimes x) \otimes y) \otimes z & & & & w \otimes (x \otimes (y \otimes z)) \\ \downarrow \alpha_{w, x, y} \otimes 1_x & & & & \uparrow 1_x \otimes \alpha_{x, y, z} \\ (w \otimes (x \otimes y)) \otimes z & \xrightarrow{\alpha_{w, x \otimes y, z}} & & & w \otimes ((x \otimes y) \otimes z) \end{array}$$

which together ensure the tensor product is unital associative up to natural isomorphism. If the associator and unitor natural transformations are identities, then \mathcal{C} is called **strict monoidal**.

That the commutative diagrams given above ensure sufficiently well-behaved unitality and associativity up to isomorphism is guaranteed by a *coherence theorem* which states all well-formed commutative diagrams involving just α , ρ , and λ commute.⁴ We can also categorify the notion of a commutative monoid as follows:

Definition 2.2. A monoidal category \mathcal{C} is called **braided** iff there exists a natural isomorphism with components $\tau_{x,y} : x \otimes y \rightarrow y \otimes x$ in $\mathcal{C}^{\mathcal{C} \times \mathcal{C}}$ called the **braiding** such that

$$\begin{array}{ccccc} & & x \otimes (y \otimes z) & & \\ & \nearrow \alpha_{x,y,z} & & \searrow \tau_{x,y \otimes z} & \\ (x \otimes y) \otimes z & & & & (y \otimes z) \otimes x \\ \downarrow \tau_{x,y} \otimes 1 & & & & \downarrow \alpha_{y,z,x} \\ (y \otimes x) \otimes z & & & & y \otimes (z \otimes x) \\ \downarrow \alpha_{y,x,z} & & & & \uparrow 1 \otimes \tau_{x,z} \\ & & y \otimes (x \otimes z) & & \end{array} \quad (2.1)$$

⁴ Mac Lane, *Categories for the Working Mathematician*, §VII.2, pp. 165–70. A coherence theorem usually implies a related *strictification theorem*, which in this case says that every monoidal category is *monoidally* (in the sense of definition 2.9) equivalent to the strict one. See Mac Lane, §XI.3, pp. 257–60.

and

$$\begin{array}{ccc}
 & (x \otimes y) \otimes z & \\
 \alpha_{x,y,z}^{-1} \nearrow & & \searrow \tau_{x \otimes y, z} \\
 x \otimes (y \otimes z) & & z \otimes (x \otimes y) \\
 1 \otimes \tau_{y,z} \downarrow & & \downarrow \alpha_{z,x,y}^{-1} \\
 x \otimes (z \otimes y) & & (z \otimes x) \otimes y \\
 \alpha_{x,z,y}^{-1} \searrow & & \nearrow \tau_{x,z} \otimes 1 \\
 & (x \otimes z) \otimes y &
 \end{array} \tag{2.2}$$

commute. Iff the braiding is involutive in the sense that $\tau_{y,x}\tau_{x,y} = 1_{x \otimes y}$, the category \mathcal{C} is called **symmetric**, and iff $\tau_{x,y}$ is the identity, \mathcal{C} is called **strictly symmetric**.⁵

The coherence theorem for symmetric monoidal categories states all well-formed commutative diagrams involving just α , ρ , λ , and τ commute.⁶ The coherence theorem for braided monoidal categories will have to wait until example 2.6.

Example 2.3. A category with finitary categorical products is called **cartesian**, Set being an example. All such categories are symmetric monoidal under the categorical product with the terminal object as the tensor unit. The same can be said for **cocartesian** categories under the categorical coproduct with the initial object as the tensor unit.⁷

We will later see another way of characterizing cartesian categories: As symmetric monoidal categories with a canonical way to duplicate data, so-called diagonal maps.

Example 2.4. Let \mathcal{C} be a category. Then the category of endofunctors $\mathcal{C}^{\mathcal{C}}$ is strictly monoidal under composition of functors, with the identity functor as the tensor unit.

Example 2.5. Let \mathcal{K} be a commutative ring. Then ${}_{\mathcal{K}}\text{Mod}$ is symmetric monoidal under the \mathcal{K} -tensor product $(\otimes_{\mathcal{K}})$ with the regular module \mathcal{K} as its tensor unit.

When we talk about ${}_{\mathcal{K}}\text{Mod}$ as a monoidal category it is almost always with reference to this structure, not the cartesian or cocartesian one. A justification for this preference is provided in §2.9.

Example 2.6. The **braid group** \mathfrak{B}_n on n strands has presentation $\langle \sigma_1, \dots, \sigma_{n-1} : R \rangle$ with R generated by the relations

$$\begin{array}{ll}
 \sigma_{i+1}\sigma_i\sigma_{i+1} = \sigma_i\sigma_j\sigma_i & \text{for } |i - j| = 1, \\
 \sigma_i\sigma_j = \sigma_j\sigma_i & \text{for } |i - j| > 1.
 \end{array}$$

As the name suggests, we depict a braid on n strands by strings travelling up the page, possibly crossing over each other, as shown in fig. 2.1. The multiplication xy of braids $x, y \in \mathfrak{B}_n$ is then represented by stacking x on top of y , and two braids are equal iff their diagrams are continuous deformations of each other.⁸ We note that

⁵ If the involutive property holds, the commutativity of eqs. (2.1) and (2.2) follow from each other.

⁶ Mac Lane, §XI.1, pp. 253–55. The corresponding strictification theorem says every symmetric monoidal category is monoidally equivalent to a strict symmetric monoidal category, and is found in Mac Lane, §XI.3, pp. 257–59.

⁷ Both these statements of course assume we are able to choose representatives of (co)product objects, which often requires some form of AC.

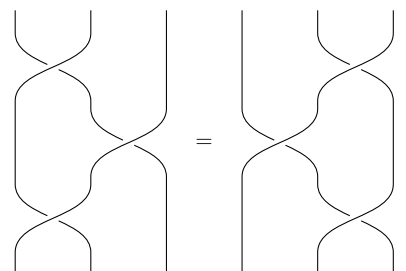

Figure 2.1: Equivalent braids $\sigma_1\sigma_2\sigma_1$ and $\sigma_2\sigma_1\sigma_2$ in \mathfrak{B}_3 .

⁸ We can alternatively construct the braid group as follows: Let $P = \mathbb{R}^2$ denote the Euclidean plane and $\binom{P}{n}$ denote the space of subsets of P of cardinality n with the natural topology. The **braid group** \mathfrak{B}_n is the fundamental group $\pi_1(\binom{P}{n})$.

forgetting which strand goes over the other in a crossing recovers the symmetric group S_n , i.e. $S_n \cong \mathfrak{B}_n/N$ where N is the normal subgroup generated by σ_i^2 for each i .

Given braids $x \in \mathfrak{B}_n$ and $y \in \mathfrak{B}_m$, we can also define the tensor product of braids $x \otimes y \in \mathfrak{B}_{n+m}$ by placing the corresponding diagrams next to each other, thus for $x = \sigma_i$ and $y = \sigma_j$ we have $\sigma_i \otimes \sigma_j = \sigma_i \sigma_{m+j}$.

We can combine all of the braid groups into the **braid category** Br by taking the coproduct of the groups-as-categories \mathfrak{B}_n . The objects $\text{Ob}(\text{Br})$ correspond to \mathbb{N}_0 , and the hom-sets $\text{Br}(m, n)$ are given by \mathfrak{B}_m iff $m = n$ and \emptyset otherwise. This category is strict monoidal under the tensor product of braids, and we form a braiding $\tau : m \otimes n \rightarrow n \otimes m$ by passing the n strands under the m strands. A simple pictorial proof of the conditions of definition 2.2 can be found in Mac Lane.⁹

⁹ Mac Lane, *Categories for the Working Mathematician*, §XI.4, pp. 260–63. Mac Lane’s convention for which strands go under which is the opposite of ours.

Braided monoidal categories in general are intimately related to the braid group and category. The coherence theorem for braided monoidal categories states that a composite of α and τ acting on an n -fold tensor product induces an element of \mathfrak{B}_n , and that two such composites are equal in all braided monoidal categories iff they are equal as elements of \mathfrak{B}_n .¹⁰

Given a monoidal category \mathcal{C} , the opposite category \mathcal{C}^{op} has a natural monoidal structure. There exists a second notion of *opposite category* which is not to be confused with \mathcal{C}^{op} . The **reversed monoidal category** by \mathcal{C}^{rev} is identical to \mathcal{C} but with a reversed order of tensor product and inverted associator. We can apply both of these operations yielding a monoidal category $\mathcal{C}^{\text{op,rev}} \cong \mathcal{C}^{\text{rev,op}}$.

¹⁰ Mac Lane, *Categories for the Working Mathematician*, §XI.5, pp. 263–66. The corresponding strictification theorem gives a monoidal equivalence between any braided monoidal category \mathcal{C} and a *generalized wreath product* $\text{Br} \wr \mathcal{C}$. For details, see Joyal and Street, “Braided Tensor Categories,” §2, pp. 33–45.

AFTER VERTICALLY CATEGORIFYING monoids, we are lead to the question of how to categorify their morphisms. Once again it is best to only require certain identities hold up to isomorphism. For example, consider the free module functor $\mathcal{K}^{(?)}$: $\text{Set} \rightarrow \mathcal{K}\text{Mod}$. While $\mathcal{K}^{\{\bullet\}}$ is not equal to \mathcal{K} , there is a canonical isomorphism $\mathcal{K}^{\{\bullet\}} \rightarrow \mathcal{K}$ defined by $\bullet \mapsto 1$, so $\mathcal{K}^{(?)}$ respects tensor units *up to isomorphism*. Similarly we have a natural isomorphism $\mathcal{K}^{(A)} \otimes \mathcal{K}^{(B)} \rightarrow \mathcal{K}^{(A \times B)}$ defined by $a \otimes b \mapsto (a, b)$ for $(a, b) \in A \times B$. This motivates the following definition:¹¹

¹¹ Mac Lane, *Categories for the Working Mathematician*, §XI.2, pp. 255–57.

Definition 2.7. Let \mathcal{C} and \mathcal{D} be monoidal categories. A functor $T : \mathcal{C} \rightarrow \mathcal{D}$ is called **monoidal** iff it is equipped with an isomorphism $\epsilon : \mathbb{1} \rightarrow T\mathbb{1}$ in \mathcal{D} and a natural isomorphism with components $\mu_{x,y} : Tx \otimes Ty \rightarrow T(x \otimes y)$ in $\mathcal{D}^{\mathcal{C} \times \mathcal{C}}$, compatible with associativity

and unitality so that

$$\begin{array}{ccc}
 & (Tx \otimes Ty) \otimes Tz & \\
 \mu_{x,y} \otimes 1 \swarrow & & \searrow \alpha_{Tx,Ty,Tz} \\
 T(x \otimes y) \otimes Tz & & Tx \otimes (Ty \otimes Tz) \\
 \mu_{x \otimes y, z} \downarrow & & \downarrow 1 \otimes \mu_{y,z} \\
 T((x \otimes y) \otimes z) & & Tx \otimes T(y \otimes z) \\
 T\alpha_{x,y,z} \searrow & & \swarrow \mu_{x,y \otimes z} \\
 & T(x \otimes (y \otimes z)) &
 \end{array}$$

and

$$\begin{array}{ccccc}
 & T(\mathbb{1} \otimes x) & & T(\mathbb{1} \otimes x) & \\
 \mu_{\mathbb{1},x} \nearrow & & T\lambda_x & & \nwarrow \mu_{x,\mathbb{1}} \\
 T\mathbb{1} \otimes Tx & & Tx & & Tx \otimes T\mathbb{1} \\
 \epsilon \otimes 1 \nwarrow & & \nearrow \lambda_{Tx} & & \swarrow \rho_{Tx} \\
 & \mathbb{1} \otimes Tx & & Tx \otimes \mathbb{1} & \\
 & & & & \nwarrow 1 \otimes \epsilon
 \end{array}$$

commute for any objects $x, y, z \in C$. If ϵ and μ are identities, then T is called **strict monoidal**. If C and D are braided, then a monoidal functor $T : C \rightarrow D$ is called **braided** iff

$$\begin{array}{ccc}
 Tx \otimes Ty & \xrightarrow{\mu_{x,y}} & T(y \otimes x) \\
 \tau \downarrow & & \downarrow T\tau \\
 Ty \otimes Tx & \xrightarrow{\mu_{y,x}} & T(y \otimes x)
 \end{array}$$

commutes for any objects $x, y \in C$.

One can thus form various categories of (small) monoidal categories, optionally restricting to braided, symmetric, or strict monoidal categories or braided or strict monoidal functors.

Proposition 2.8. *Let \mathcal{K} be a commutative ring. Then the free functor $K^{(?) : \text{Set}} \rightarrow \mathcal{K}\text{Mod}$ is braided monoidal.*

Complete categorification of monoids must also consider what it means for a natural transformation to respect monoidal structure.

Definition 2.9. A natural transformation $\gamma : T_1 \Rightarrow T_2 : C \rightarrow D$ between monoidal functors is called **monoidal** iff

$$\begin{array}{ccc}
 T_1(x) \otimes T_1(y) & \xrightarrow{\gamma_x \otimes \gamma_y} & T_2(x) \otimes T_2(y) \\
 (\mu_1)_{x,y} \downarrow & & \downarrow (\mu_2)_{x,y} \\
 T_1(x \otimes y) & \xrightarrow{\gamma_{x \otimes y}} & T_2(x \otimes y)
 \end{array}$$

and

$$\begin{array}{ccc}
 & \mathbb{1} & \\
 \epsilon_1 \swarrow & & \searrow \epsilon_2 \\
 T_1(\mathbb{1}) & \xrightarrow{\gamma_{\mathbb{1}}} & T_2(\mathbb{1})
 \end{array}$$

commute for any objects $x, y \in C$.

A **monoidal equivalence** is an equivalence of categories such that the functors involved are all monoidal.

2.2 Monoids, first definition

Monoidal categories feature extensively in applications of category theory, in part because their rich structure provides a good environment for internalization. One need only replace cartesian products with general tensor products, elements with morphisms from the tensor unit, and express defining identities in terms of commutative diagrams.

Definition 2.10. Let C be a monoidal category. A **monoid** in C consists of the data

$$1 \xrightarrow{e} M \xleftarrow{m} M \otimes M$$

where e is called the unit and m is called the **multiplication**, and these satisfy the left/right unit laws

$$\begin{array}{ccccc} 1 \otimes M & \xrightarrow{e \otimes 1} & M \otimes M & \xleftarrow{1 \otimes e} & M \otimes 1 \\ & \searrow \lambda & \downarrow m & \swarrow \rho & \\ & & M & & \end{array}$$

and the associative law

$$\begin{array}{ccc} & M \otimes (M \otimes M) & \\ \alpha \nearrow & & \searrow 1 \otimes m \\ (M \otimes M) \otimes M & & M \otimes M \\ \downarrow m \otimes 1 & & \downarrow m \\ M \otimes M & \xrightarrow{m} & M \end{array}$$

Moreover, if C is symmetric monoidal,¹² then a monoid is **commutative** iff it additionally satisfies the commutative law

$$\begin{array}{ccc} M \otimes M & \xrightarrow{\tau} & M \otimes M \\ & \searrow m & \swarrow m \\ & M & \end{array}$$

It is clear that a (commutative) monoid in the cartesian category Set gives the ordinary notion of a (commutative) monoid. In $\mathcal{K}\text{Mod}$, we get what is usually called a (commutative) unital associative \mathcal{K} -algebra. For the sake of brevity and consistency, we adopt the term (commutative) \mathcal{K} -monoid. In particular, \mathbb{Z} -monoids (i.e. monoids in Ab) are precisely rings. We will revisit monoids with a more developed toolkit in §2.4.

¹² There is something neat about the fact that the appropriate environment to define a monoid is a *monoidal category*, that the appropriate environment to define a commutative monoid is a *symmetric monoidal category* — this has been termed the *microcosm principle* in Baez and Dolan, “Higher-Dimensional Algebra III: n -Categories and the Algebra of Opetopes.”

2.3 String diagrams in monoidal categories

Already in definition 2.10 we find commutative diagrams a bit unwieldy. Part of the problem is the clutter introduced by invoking the associator, unitor, and braiding natural isomorphisms. We would like to be able to sweep these under the rug, so to speak, seeing that, for our purposes, associativity and unitality up to isomorphism are almost just as good as the real thing.

String diagrams are a convenient language for manipulating morphisms and objects in monoidal categories, not least because associativity and unitality is baked in to their very topology. In their most general form, string diagrams may be applied to any bicategory.¹³ Here we develop this simpler case for monoidal categories as first developed by Joyal and Street.¹⁴ This subsumes Hotz’s notation for automata, Penrose’s notation for tensor networks, quantum circuit diagrams, ZX-calculus, and Cvitanović’s Birdtracks.¹⁵

THE EPONYMOUS STRINGS of string diagrams represent objects in the ambient category, e.g. sets or vector spaces. Often we will use colours instead of labelling strings directly. Morphisms

$$R \xrightarrow{f} B, \quad B \xrightarrow{g} P$$

are then vertices with appropriate strings for the domain and codomain

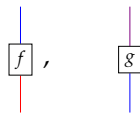

so that vertical composition is represented by vertical stacking of diagrams.¹⁶

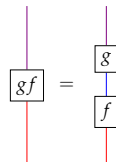

Using our objects as identities perspective, an identity morphism is written as the empty string for the corresponding object.¹⁷

Horizontal composition (i.e. the tensor product) is then represented by horizontal stacking of diagrams, thus

$$R \otimes B \xrightarrow{f \otimes g} B \otimes P$$

is written as

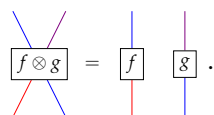

Note that associators are necessarily implicit, since we have no way of differentiating between $(R \otimes B) \otimes P$ and $R \otimes (B \otimes P)$. We make the unitors implicit by representing the tensor unit $\mathbb{1}$ as the empty diagram. Thus a morphism $x : \mathbb{1} \rightarrow R$ is written as¹⁸

¹³ A bicategory is a sort of *horizontal categorification* of a monoidal category, possessing objects, morphisms, and morphisms of morphisms. String diagrams can be used here for defining adjunction of functors and even generalizing adjointness. For a development of string diagrams in this full generality, See e.g. Street, “Categorical Structures.”

¹⁴ Joyal and Street, “The Geometry of Tensor Calculus, I.”

¹⁵ Hotz, “Eine Algebraisierung Des Syntheseproblems von Schaltkreisen I”; Coecke and Kissinger, *Picturing Quantum Processes*; Cvitanović, *Group Theory*.

¹⁶ This work follows the category theoretic convention where string diagrams are read from the bottom up.

¹⁷ Already we see how algebraic rules are naturally encoded in the geometry of string diagrams, e.g. that one can always precompose or postcompose a morphism with an appropriate identity morphism without changing the result.

¹⁸ Typically the shape of a morphism is stylistic and not semantic, though occasionally we use distinct shapes instead of labels for special morphisms.



Finally, when the ambient category is *braided* monoidal, we represent the braiding by crossing wires, so

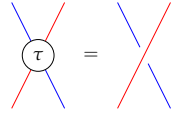

where we omit showing the gap (i.e. which string goes under the other) in the symmetric case.

THE RAISON D'ÊTRE of string diagrams is that they are *isotopy-invariant*: Two string diagrams encode the same morphism if they are related by a continuous deformation.¹⁹ For example, the interchange law $(f \otimes 1)(1 \otimes g) = (1 \otimes g)(f \otimes 1)$ is expressed as

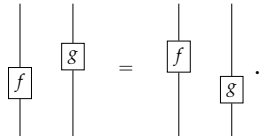

To see why this is useful, consider the expressions

$$w_1 := (1 \otimes c \otimes d)(1 \otimes 1 \otimes b \otimes 1)(a \otimes 1 \otimes 1)$$

$$w_2 := (1 \otimes 1 \otimes d)(1 \otimes c \otimes 1 \otimes 1)(a \otimes b \otimes 1).$$

These are in fact equal, which becomes obvious after one draws the corresponding string diagrams as shown in fig. 2.2.

The correctness of string diagrams in this sense, first articulated and proven by Joyal and Street, can be seen as a geometric counterpart to the various algebraic coherence theorems already discussed. As the authors note,

Penrose was the first to use the graphical notation for calculating with tensors. It is now currently used by theoretical physicists as a private device for quickly verifying complicated tensor formulas. A striking aspect of this notation is that it is pictorial rather than sequential or alphabetical. This made it difficult to print, which partly explains why no rigorous theory was developed. We believe that a notation which is useful in private must be given a public value and that it should be provided with a firm theoretic foundation. Furthermore, printing techniques have improved drastically in recent years.²⁰

¹⁹ We can view string diagrams as unbraided, braided, and symmetric monoidal categories as graphs embedded in 2-, 3-, and 4-dimensional space respectively. The triviality of a symmetric braiding reflects the famous result that there are no nontrivial knots in 4 dimensions.

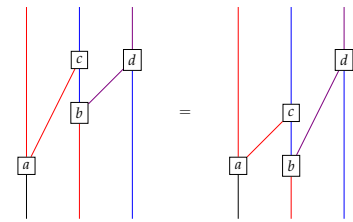

Figure 2.2: Equal composite morphisms in a monoidal category.

²⁰ Joyal and Street, "The Geometry of Tensor Calculus, I," p. 1.

2.4 Monoids, second definition

We now have everything we need to revisit the definition of a monoid in a monoidal category.

Definition 2.11. Let C be a monoidal category. A **monoid** in C consists of the data

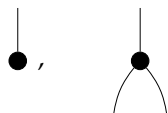

called the **unit** and **multiplication** respectively, and these satisfy the left/right unit laws

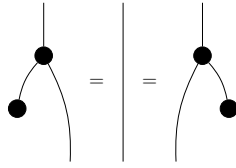

and the associative law²¹

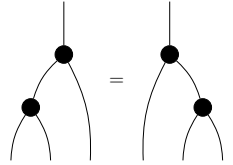

Moreover, if C is symmetric monoidal, then a monoid is **commutative** iff it additionally satisfies the commutative law

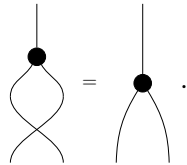

The usual argument that a units are uniquely determined for a given multiplication extends easily to general monoids. Note we have a canonical monoid structure on $\mathbb{1}$, where the unit is given by the morphism $1_{\mathbb{1}}$ and the multiplication is given by the unitor natural transformations $\lambda_{\mathbb{1}} = \rho_{\mathbb{1}}$.²² The triviality of this structure, which we will call the **unit monoid** in C , is reflected notationally in the fact that all its data are empty string diagrams.²³

A **monoid morphism** $f \in C(R, B)$ is simply a morphism which respects the unit and multiplication. In terms of string diagrams, this means

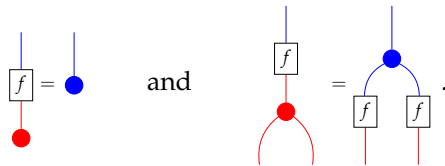

For each monoidal category C we can thus form a corresponding category Mon_C of monoids therein.²⁴

Now if the ambient category C is symmetric, the tensor product of monoids has a natural unit and multiplication given by

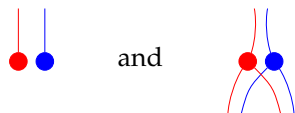

respectively. Moreover, the tensor product of monoid morphisms is a monoid morphism of the appropriate product monoids. This makes Mon_C into a monoidal category, with the unit monoid as the tensor unit. A stronger statement holds:

²¹ Thanks to associativity, we can unambiguously define **iterated multiplication** going from any number of input strings to a single output string, e.g.

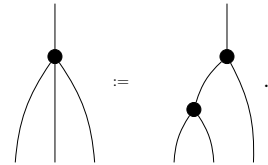

By unitality, this is consistent with our notation for the unit as iterated multiplication with zero input strings.

²² This equality follows from coherence.

²³ In Set , this is the trivial monoid. In ${}_{\mathcal{K}}\text{Mod}$, this corresponds to viewing the ground ring \mathcal{K} as a \mathcal{K} -monoid under ring multiplication.

²⁴ Following our convention that we sometimes use \mathcal{K} as a substitute for ${}_{\mathcal{K}}\text{Mod}$, we denote the category of \mathcal{K} -monoids as $\text{Mon}_{\mathcal{K}}$.

Proposition 2.12. *If \mathcal{C} is a symmetric monoidal category, $\text{Mon}_{\mathcal{C}}$ is co-cartesian under the tensor product of monoids.*

Proof. Suppose R, B are monoids in \mathcal{C} . We define monoid morphisms

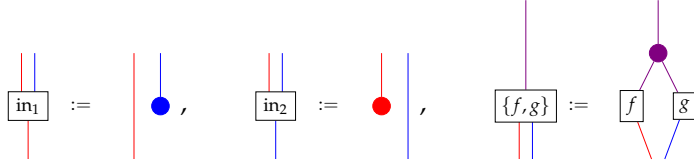

and claim these satisfy the universal property of the coproduct. Namely, if $f : R \rightarrow P$ and $g : B \rightarrow P$ are monoid morphisms in \mathcal{C} , then we claim $\{f, g\}$ is the unique monoid morphism such that

$$\begin{array}{ccccc}
 & & P & & \\
 & f \nearrow & \uparrow \{f,g\} & \nwarrow g & \\
 R & \xrightarrow{\text{in}_1} & R \otimes B & \xleftarrow{\text{in}_2} & B
 \end{array} \tag{2.3}$$

commutes.²⁵ Suppose that $h : R \otimes B \rightarrow P$ makes eq. (2.3) commute. Then

²⁵ cf. fig. 1.6.

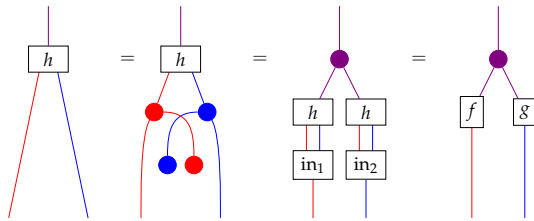

so $h = \{f, g\}$ as required. □

If X is a monoid in a symmetric monoidal category \mathcal{C} , we can define the **opposite monoid** X^{op} on the same object with the same unit and the opposite multiplication shown in fig. 2.3. Thus X is commutative iff $X = X^{\text{op}}$. Given a monoid morphism $f : X \rightarrow Y$, we can define $f^{\text{op}} : X^{\text{op}} \rightarrow Y^{\text{op}}$ to be the same morphism in \mathcal{C} . This makes ${}^{\text{op}} : \text{Mon}_{\mathcal{C}} \rightarrow \text{Mon}_{\mathcal{C}}$ an endofunctor, involutive due to \mathcal{C} being symmetric.²⁶

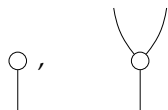

Figure 2.3: The multiplication for the opposite monoid X^{op} .

2.5 Comonoids

In §2.1 we noted if \mathcal{C} is a monoidal category under (\otimes) , then so too is \mathcal{C}^{op} under (\otimes^{op}) . A monoid in \mathcal{C}^{op} is called a **comonoid** in \mathcal{C} . Duality in commutative diagrams corresponds to flipping arrows; we turn string diagrams upside down.

Definition 2.13. Let \mathcal{C} be a monoidal category. A **comonoid** in \mathcal{C} consists of the data



²⁶ A monoid morphism $f : X^{\text{op}} \rightarrow Y$ is equivalent to what is sometimes called an *antihomomorphism* $f : X \rightarrow Y$. Mirroring our convention for covariant and contravariant functors, we will invoke opposite monoids rather than refer to antihomomorphisms.

called the **coünit** and **comultiplication** respectively, and these satisfy the left/right coünit laws

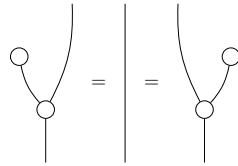

and the coassociative law²⁷

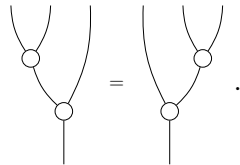

Moreover, if C is symmetric monoidal, then a monoid is **cocommutative** iff it additionally satisfies the commutative law

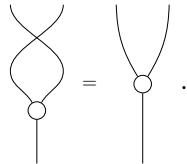

Comonoid morphisms and tensor products of comonoids are defined analogously, so that $\text{Comon}_C = \text{Mon}_{C^{\text{op}}}^{\text{op}}$ is the category of comonoids in a monoidal category C . The dual of proposition 2.12 says Comon_C is cartesian when C is symmetric monoidal. In a symmetric monoidal category C , the **coöpposite comonoid** X^{cop} of a comonoid X is defined analogously to the opposite monoid, giving a structure on the same object with the same coünit and the opposite comultiplication showed in fig. 2.4.

Loosely speaking, comultiplication gives a way to duplicate data, while the coünit gives a way to destroy data. We therefore expect diagonal maps in cartesian categories to define valid comultiplications. In fact a stronger statement holds:

Proposition 2.14. *Let X be an object in a cartesian category C . Then X is a comonoid in a unique way, where the coünit is the unique terminal map and the multiplication is the diagonal map $(1, 1) : X \rightarrow X \times X$. It follows X is cocommutative.²⁸ Moreover, every morphism in C is a comonoid morphism with respect to this unique structure.*

Proof. The coünit must be thus since $\mathbb{1}$ is terminal, and by the same token every morphism in C preserves this coünit, Coünitality fixes the comultiplication to be $(1, 1)$ by the universal property of the product. Coassociativity and cocommutativity then follow from the associativity and symmetry of C . □

A theorem due to Fox gives the converse that a symmetric monoidal category C is cartesian iff it is monoidally equivalent to its category of comonoids.²⁹ In a general monoidal category, we expect comonoids to be just as diverse as monoids. Indeed, one way of viewing comonoids is as attaching the extra datum of a “diagonal map” to an object which may lack a canonical one.

²⁷ As with associativity, coassociativity allows us to unambiguously defined **iterated comultiplication** going from one input string to any number of output strings, e.g.

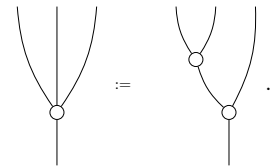

Once again, coünitality means this is consistent with the notation for the coünit as comultiplication with zero output strings.



Figure 2.4: The comultiplication for the coöpposite comonoid X^{cop} .

²⁸ By duality, in a cocartesian category every object is a monoid in a unique, commutative way. This gives another reason the cartesian structure on $\mathcal{K}\text{Mod}$, which is simultaneously cocartesian, is not as interesting as the tensor product.

²⁹ Fox, “Coalgebras and Cartesian Categories.”

2.6 Modules

All the instances of internalization explored thus far have begun with a definition in the category Set . For modules, we start with the category Ab . As previously remarked, monoids in Ab are precisely rings, so a module over a ring is internalized as a module over a monoid.

Definition 2.15. Let \mathcal{C} be a monoidal category and $X \in \mathcal{C}$ be a monoid. A (left) X -**module** in \mathcal{C} is an object $R \in \mathcal{C}$ equipped with a left X -**action**

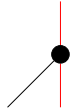

such that³⁰

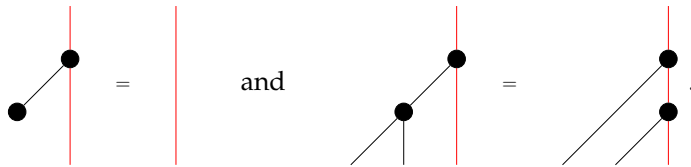

³⁰ We can thus unambiguously define iterated actions for an arbitrary number of monoid strings on a single module string, for example

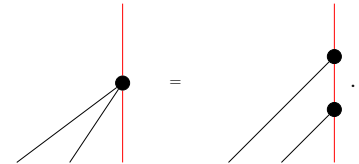

Example 2.16. Let X be a ring, i.e. a monoid in Ab . An X -module in Ab is precisely an X -module in the classical sense.

Example 2.17. Let G be a group in the classical sense. Then G is a monoid in Set . A G -module in Set is precisely a G -set, i.e. a set equipped with a group action.

Example 2.18. For a monoid $X \in \mathcal{C}$ we see that X is itself an X -module with the action given by its multiplication. We call this the **regular X -module**.

The corresponding definition for module morphisms is obvious: If R, B are X -modules in \mathcal{C} , then a morphism $f : R \rightarrow B$ is an X -module morphism iff

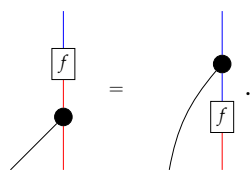

Thus for any monoid X in \mathcal{C} we can define the category ${}_{\mathcal{C}}X\text{Mod}$ of X -modules in \mathcal{C} , writing ${}_X\text{Mod}$ for $\mathcal{C} = \text{Ab}$. These categories come equipped with forgetful functors ${}_{\mathcal{C}}X\text{Mod} \rightarrow \mathcal{C}$.

Proposition 2.19. Let \mathcal{K} be a commutative ring and \mathcal{A} be a \mathcal{K} -monoid. Then the categories ${}_{\mathcal{K}}\mathcal{A}\text{Mod}$ and ${}_{\mathcal{A}}\mathcal{K}\text{Mod}$ are identical.

Proof. The category ${}_{\mathcal{A}}\mathcal{K}\text{Mod}$ are defined to have \mathcal{K} -bilinear actions on its modules and \mathcal{K} -linear morphisms, which are automatically \mathbb{Z} -(bi)linear. Thus every module and morphism in the former category is in the latter. For the converse, suppose V is a (classical) module over \mathcal{A} . Then it is also a module over \mathcal{K} , by the action $k \triangleright v = k1 \triangleright v$ for $k \in \mathcal{K}$, where $k1 \in \mathcal{A}$. Similarly, if $f : V \rightarrow W$ is \mathcal{A} -linear then it is automatically \mathcal{K} -linear by the same token. \square

2.7 Bimonoids

In a symmetric monoidal category, it is possible for an object to carry compatible monoid and comonoid structure, so that the counit and comultiplication are monoid morphisms.

Definition 2.20. Let \mathcal{C} be a symmetric monoidal category. A **bimonoid** is a comonoid in the cocartesian category $\text{Mon}_{\mathcal{C}}$, or equivalently a monoid in the cartesian category $\text{Comon}_{\mathcal{C}}$.

In terms of string diagrams this compatibility of monoid and comonoid structures is expressed by the self-dual set of diagrams in fig. 2.5. A bimonoid morphism is a morphism in \mathcal{C} which is both a monoid and comonoid morphism, and together these form the category $\text{Bimon}_{\mathcal{C}}$.

Example 2.21. Consider the \mathcal{K} -monoid $\mathcal{K}[x]$ of polynomials in indeterminate x . Up to \mathcal{K} -monoid isomorphism, there are exactly two bimonoid structures on $\mathcal{K}[x]$, determined by the comultiplications

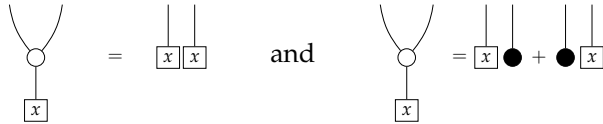

respectively.³¹

Since we have ensured no overlap between our monoid and comonoid terminology, we can unambiguously use these descriptors on a bimonoid to refer to either the monoid or comonoid structure. For example a “noncommutative cocommutative bimonoid” is noncommutative as a monoid and cocommutative as a comonoid. Given a bimonoid X , we can talk about the opposite bimonoid X^{op} , the coöpposite bimonoid X^{op} , or the opposite coöpposite bimonoid $X^{\text{op, cop}}$.

Given a comonoid R and monoid B in a monoidal category \mathcal{C} , the hom-set $\mathcal{C}(R, B)$ forms a monoid with multiplication and unit given by

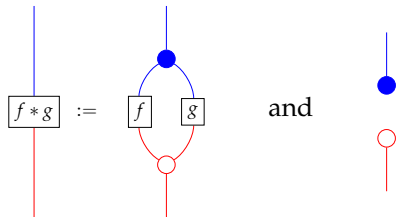

respectively, where the operation $(*)$ is known as the **convolution**. We often use this in proofs. In particular, $\text{End}_{\mathcal{C}}(H)$ is a monoid under either convolution or composition for a bimonoid H .

2.8 Internalizing groups: Hopf monoids

In this section we wish to carry out the internalization process for a group. It would seem the bulk of the work has already been done in the preceding sections. After all, a group G is a monoid with a

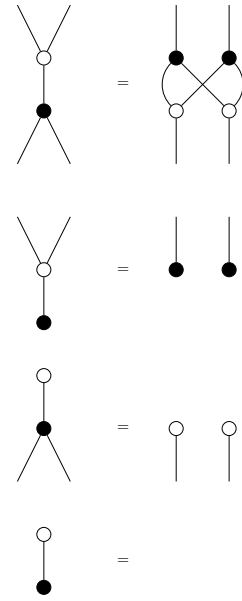

Figure 2.5: String diagrams for the bimonoid compatibility conditions.

³¹ Underwood, *Fundamentals of Hopf Algebras*, §2.1, p. 37.

little bit of extra structure: An inversion operation $\sigma : G \rightarrow G : x \mapsto x^{-1}$ satisfying the identity $xx^{-1} = 1 = x^{-1}x$ for all $x \in G$. Unfortunately this formulation is already impossible to give in a general monoidal category, since it involves *duplicating data* by implicitly invoking the diagonal map.³²

A solution to this problem is hinted at by the discussion in §2.5. Since there does not exist a universal diagonal map in a general monoidal category C , we simply demand that this be specified on an object-by-object basis as extra data — the data of a comonoid. This motivates the following definition, which can be viewed as a generalized internalization of a group to an arbitrary symmetric monoidal category:

Definition 2.22. Let C be a symmetric monoidal category. A **Hopf monoid** H in C is a bimonoid equipped with a morphism $\sigma \in C(H, H)$ called the **antipous**³³ satisfying the antipous law

If σ is invertible, H is called an **autonomous Hopf monoid**.³⁴

In Set , eq. (2.4) reduces to $xx^{-1} = 1 = x^{-1}x$ and Hopf monoids are thus precisely groups. The benefit of this formulation is that it can be imported into any category, and in particular, $\mathcal{K}\text{Mod}$, where we call a Hopf monoid a **Hopf \mathcal{K} -algebra**. The ubiquity of Hopf algebras will become clear in §3.

An important property of the definition of Hopf monoids, and for that matter bimonoids too, is that it is formally self dual: Every Hopf monoid in C is a Hopf monoid in C^{op} . If we prove something about the monoid structure of a general Hopf monoid, then we get a statement about its comonoid structure for free. We will use this to shorten proofs.

Outside of universal algebra, groups are typically thought of as defined in terms of their multiplication and elements alone, as units and inverses, when they exist, are completely determined by this structure. A similar statement holds for general Hopf monoids.

Proposition 2.23. *Let H be a bimonoid in C . Then there exists at most one antipous σ on H such that these form a Hopf monoid.*

Proof. Consider the convolution monoid $\text{End}_C(H)$. The antipous is the two-sided inverse of the identity morphism $1_H \in \text{End}_C(H)$, and is thus unique if it exists. □

Proposition 2.24. *Let R, B be Hopf monoids in C and $f : R \rightarrow B$ be a bimonoid morphism. Then f commutes with antipodes, as shown in fig. 2.6.*

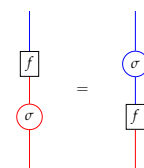

Figure 2.6: A morphism commuting with antipodes.

³² And more subtly, *deleting data*.

³³ *Antipous* is the Greek singular of the more familiar plural *antipodes*, although many authors use the back-formation *antipode* as the singular.

³⁴ Most Hopf monoids of interest to us are autonomous, see theorem 2.44.

Proof. Consider f as an element of the convolution monoid $C(R, B)$. Since

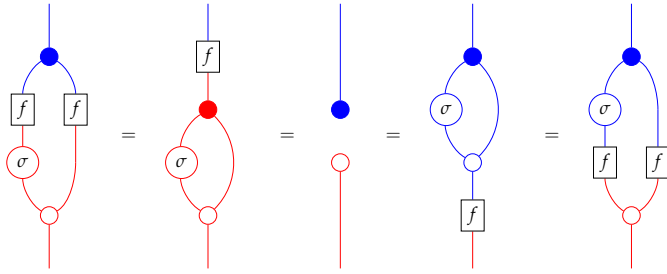

both $f\sigma$ and σf are convolution preinverses for f , and a symmetric argument shows they are both convolution postinverses for f . Thus by uniqueness of two-sided inverses, the two are equal. \square

Hence a morphism of Hopf monoids $f : A \rightarrow B$ is defined as a morphism of the underlying bimonoids. Given a symmetric monoidal category C , we denote the category of Hopf monoids and their morphisms as Hopf_C . In particular, $\text{Hopf}_{\text{Set}} \cong \text{Grp}$.

The following result generalizes the fact that group inversion is an isomorphism to the opposite group.

Proposition 2.25. *Let H be a Hopf monoid with antipous σ . Then $\sigma : H^{\text{op}, \text{cop}} \rightarrow H$ is a bimonoid morphism.*

Proof. By self-duality it suffices to prove that $\sigma : H^{\text{op}} \rightarrow H$ is a monoid morphism. To this end, consider the convolution monoid $C(H \otimes H, H)$, and let $\mu \in C(H \otimes H, H)$ denote the multiplication of H . Note that the pullback $\mu^* = C(\mu, H) : C(H, H) \rightarrow C(H \otimes H, H)$ is a convolution monoid morphism since μ is a comonoid morphism. It follows that $\mu^*(\sigma) = \sigma\mu$ is the convolution inverse of $\mu^*(1_H) = \mu$. On the other hand the right hand side of fig. 2.7 is a convolution inverse, since

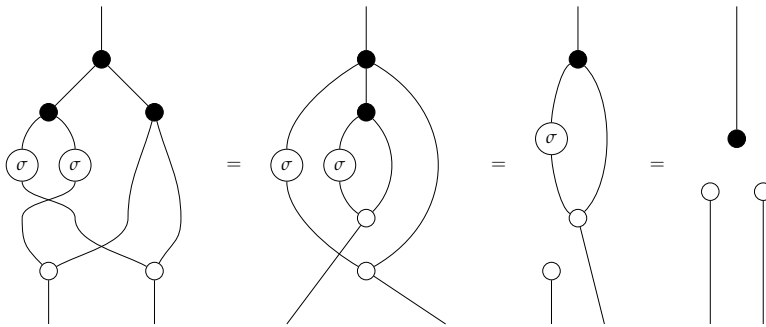

so by uniqueness of two-sided inverses the equality in fig. 2.7 holds. We also have

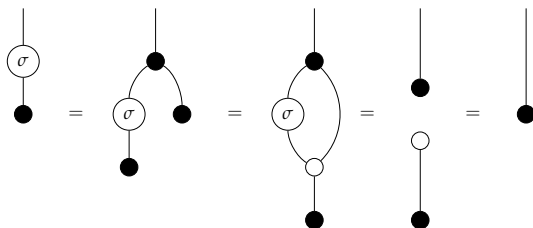

as required.³⁵

\square

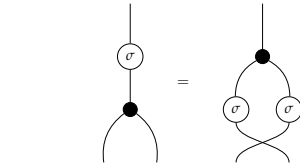

Figure 2.7: This equality, along with leaving the unit invariant, is necessary and sufficient for $\sigma : H^{\text{op}} \rightarrow H$ to be a monoid morphism.

³⁵ Joyal and Street, “An Introduction to Tannaka Duality and Quantum Groups,” pp. 466–67.

An autonomous Hopf monoid is called **involutive** iff $\sigma = \sigma^{-1}$. Unlike for groups, this need not be the case for a general Hopf monoid.

Proposition 2.26. *Let H be a Hopf monoid. If H is commutative or cocommutative, then it is involutive.*

Proof. By self-duality it suffices to prove the cocommutative case. Suppose H is cocommutative. Then by proposition 2.25,

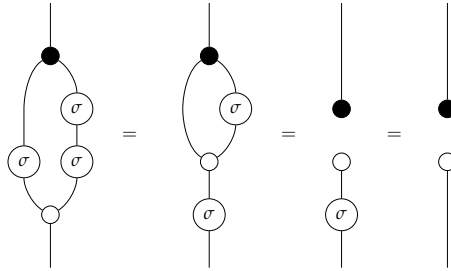

so σ^2 is a convolution inverse of σ . By uniqueness of inverses, $\sigma^2 = 1_H$. □

2.9 Closed categories

In a sense monoidal structure introduced in §2.1 is a substitute for the cartesian product in Set . In a similar vain, closed structure provides a substitute for the internal hom-functor. Defining *closed categories* in their full generality would take us too far, see e.g. Eilenberg and Kelly.³⁶ Fortunately, in the cases of interest to us, closed structure interacts nicely with symmetric monoidal structure and this actually simplifies the definition.

³⁶ Eilenberg and Kelly, “Closed Categories.”

Definition 2.27. A category C is left **closed monoidal** iff it is monoidal and for any object $B \in C$ the left tensor product functor $? \otimes B : C \rightarrow C$ has a right adjoint $B \multimap ? : C \rightarrow C$ called the **internal hom**. If the given monoidal structure is cartesian, then C is called **cartesian closed** and an internal hom-object is denoted $C^B = B \multimap C$ and called an **exponential object**.

It is not difficult to show that the internal hom extends to a bifunctor $(\multimap) : C^{\text{op}} \times C \rightarrow C$. Unravelling the adjunction in definition 2.27, we get a natural bijection of hom-sets

$$C(A \otimes B, C) \cong C(A, B \multimap C), \tag{2.5}$$

an operation known to computer scientists and logicians as *currying*, and as partial application to others.³⁷ The counit of this adjunction is a natural transformation with components $\text{ev}_C^B : (B \multimap C) \otimes B \rightarrow C$ and is naturally interpreted as **evaluation**.³⁸ As such, we name the unit $\text{coev}_C^B : C \rightarrow B \multimap (C \otimes B)$ **coevaluation**.

³⁷ To understand eq. (2.5), it may be helpful to use the familiar context of the cartesian category Set : Functions $A \times B \rightarrow C$ are the same as functions taking in an argument from A and returning functions $B \rightarrow C$.

We can now state why the tensor product on $\mathcal{K}\text{Mod}$ gives a more suitable monoidal structure: It is this bifunctor, and not the cartesian product, which is a left adjoint of the internal hom for $\mathcal{K}\text{Mod}$. This is of course related via currying to the fact that multilinear maps correspond to linear maps from tensor product modules.

³⁸ It is possible to describe a condition called *extranaturality*, so that ev_C^B is extranatural in B and natural in C .

2.10 Dual objects and autonomous categories

Conspicuously absent from §2.9 were string diagrams. While various string diagrammatic notations for internal-homs exist,³⁹ these quickly become very complicated. The situation is much nicer in categories like $\text{Vect}_{(\mathbb{K})}$, where arbitrary internal homs can be reconstructed from $? \multimap \mathbb{1}$ via the natural isomorphism

$$V \multimap W \cong V^* \otimes W$$

where $V^* = V \multimap \mathbb{1}$ is the dual vector space. We can define dual objects in general monoidal categories as follows:

Definition 2.28. Let X and Y be objects in a monoidal category, where we write these as strings directed upwards and downwards respectively. A **duality** $Y \dashv X$ consists of morphisms

$$\begin{aligned} \text{ev}_X &= \begin{array}{c} \text{---} \\ \downarrow \\ \uparrow \\ \text{---} \end{array} : Y \otimes X \rightarrow \mathbb{1}, \\ \text{coev}_X &= \begin{array}{c} \uparrow \\ \downarrow \\ \text{---} \end{array} : \mathbb{1} \rightarrow X \otimes Y \end{aligned}$$

called **evaluation** and **coevaluation** satisfying the zigzag identities

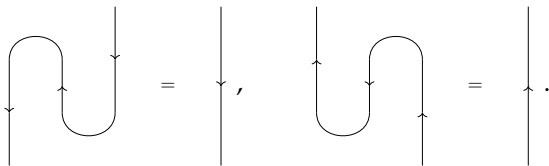

We thence call Y a right dual of X and X a left dual of Y . An object with a left or right dual is called **dualizable**.⁴⁰

Proposition 2.29. *Left and right duals are unique up to unique isomorphism.*

Proof. We prove the right case, the left case is symmetrical. Suppose $X \dashv Y$ with the notation of definition 2.28 but also $X \dashv R$ so that

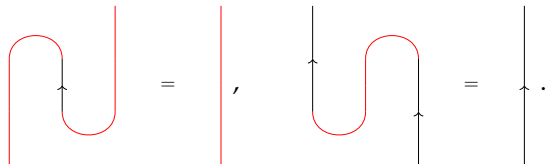

Letting

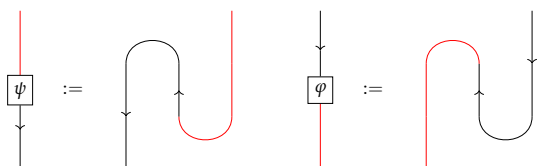

³⁹ See e.g. Alvarez-Picallo et al., “Rewriting for Monoidal Closed Categories”; Baez and Stay, “Physics, Topology, Logic and Computation,” §2.2.6, pp. 125–30.

⁴⁰ The resemblance to adjunction of functors goes beyond choice of notation. By considering a monoidal category as a single object bicategory, duality and adjunction become the same concept. See also corollary 2.33.

we have

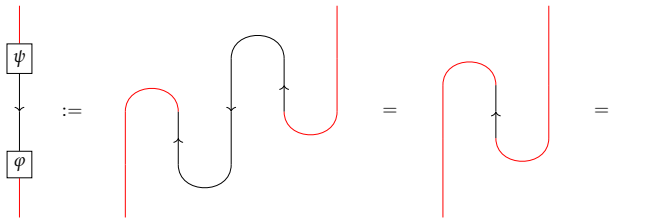

i.e. $\psi\phi = 1_R$. A symmetrical argument shows $\phi\psi = 1_{X^*}$, whence ϕ is an isomorphism. Moreover, ϕ is uniquely determined by the compatibility conditions

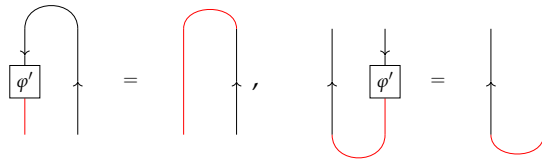

since then the zigzag identities give precisely $\phi' = \psi^{-1}$ and thus by uniqueness of inverses $\phi = \phi'$.⁴¹ □

We therefore speak of *the* left dual X^* or right dual *X of an object $X \in C$.⁴² We will also call an object a left or right dual if it has a right or left dual respectively. From now on, we will reserve the notation of *caps* and *cups* for evaluation and coevaluation respectively, usually drawing objects and their duals with the same coloured strings when the meaning is clear from context and direction of arrows on strings.

Of course, duals need not exist for all objects in a general monoidal category. For example, in the cartesian category Set only dualizable object is $\mathbb{1} = \{\bullet\}$ which is its own dual.⁴³

Definition 2.30. A **left or right rigid category** C is a monoidal category such that every object $X \in C$ has a canonical left dual X^* or right dual *X respectively. An **autonomous category** is both left and right rigid.

If R and B are right duals, and $f : R \rightarrow B$ is a morphism, we can define the left dual $f^* : B^* \rightarrow R^*$ as shown in fig. 2.8, and the right dual can be defined similarly. Moreover, the left dual of $R \otimes B$ is naturally isomorphic to $B^* \otimes R^*$ where evaluation and coevaluation are as in fig. 2.9. This means that in any autonomous category, we can extend left duals to a functor $(?^*) : C^{\text{op,rev}} \rightarrow C$, with an essential inverse given by right duals. Note, however, we do not in general have $(?^*)^* \simeq 1_C$ as in $\text{Vect}_{(\mathbb{K})}$, or, what is the same, $?^* \simeq ?$.

Definition 2.31. A **pivotal category** is an autonomous category such that left and right duals coincide, i.e. $?^* \simeq ?$.

String diagrams for autonomous and pivotal categories were introduced by Joyal and Street and allow wires to be bent back on themselves in the vertical direction.⁴⁴ There is a striking resemblance to Feynman diagrams such as fig. 2.10, where an antiparticle

⁴¹ A more abstract proof exists using corollary 2.33 and the Yoneda lemma, but gives less insight.

⁴² Caveat emptor, the conventions for notation and terminology vary a lot here. We have chosen our left and right duals to be consistent with our notions of left and right adjoints, and the asterisk is placed to be on the inside of evaluation $X^* \otimes X \rightarrow \mathbb{1}$ and outside of coevaluation $\mathbb{1} \rightarrow X \otimes X^*$.

⁴³ The unit of a monoidal category will always be self-dual, as one can express the unit, counit, and zigzag identities as empty string diagrams.

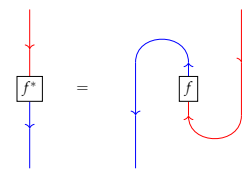

Figure 2.8: The right dual of a morphism $f : R \rightarrow B$.

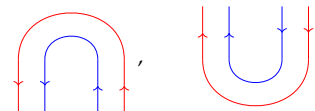

Figure 2.9: The evaluation and coevaluation for the tensor product of dualizable objects.

⁴⁴ Joyal and Street, “Planar Diagrams and Tensor Algebra.”

is analogous to dual a object, and particle-antiparticle annihilation and creation are analogous to evaluation and coevaluation.

As suggested at the start of the section, we can use duals to construct internal homs:

Proposition 2.32. *Let C be a left rigid category. Then C is left closed monoidal, with the internal hom*

$$R \multimap B = B \otimes R^*.$$

and evaluation shown in fig. 2.11.

Proof. Recall that evaluation is the counit of the tensor-hom adjunction. Thus it suffices to demonstrate that for any $B, R, P \in C$ and morphism appropriate morphism g there is a unique adjunct g^b for which

$$\begin{array}{ccc}
 B \otimes R^* \otimes R & \xrightarrow{\text{ev}_B^R} & B \\
 \uparrow g^b \otimes R & \nearrow g & \\
 P \otimes R & & \\
 & & \exists! g^b \\
 & & P \xrightarrow{\quad} B \otimes R^*
 \end{array} \tag{2.6}$$

commutes. Now if there exists g^b making eq. (2.6) commute

$$\begin{array}{ccc}
 \begin{array}{c} \uparrow \\ \downarrow \\ \boxed{g^b} \\ \uparrow \\ \downarrow \end{array} & = & \begin{array}{c} \uparrow \\ \downarrow \\ \boxed{g^b} \\ \uparrow \\ \downarrow \end{array} \\
 & & \begin{array}{c} \uparrow \\ \downarrow \\ \uparrow \\ \downarrow \end{array} \\
 & = & \begin{array}{c} \uparrow \\ \downarrow \\ \boxed{g} \\ \uparrow \\ \downarrow \end{array} \\
 & & \begin{array}{c} \uparrow \\ \downarrow \end{array}
 \end{array} \tag{2.7}$$

where the first equality is by the first zigzag identity and the second is by commutivity of eq. (2.6), and indeed the diagram on the right gives a valid adjunct — it exists and is unique. \square

Corollary 2.33. *Let C be a monoidal category and suppose $A^* \dashv A$. Then we have an adjunction of functors $? \otimes A \dashv ? \otimes A^*$.⁴⁵*

Proof. Equation (2.6) shows ev_B^R is a counit of this adjunction as well. \square

Corollary 2.34. *Let C be a left closed monoidal category and suppose A is a right dual. Then A^* is naturally isomorphic to $A \multimap \mathbb{1}$.*

Proof. By uniqueness of adjoints, $?^* \simeq \mathbb{1} \otimes ?^* \simeq ? \multimap \mathbb{1}$. \square

2.11 The pivotal symmetric category $\text{Vect}_{(\mathbb{K})}$

Now that we are equipped with a rich arsenal of tools for dealing with monoidal categories, we turn our attention to the case of $\text{Vect}_{(\mathbb{K})}$. We have already established that this is symmetric monoidal under the \mathbb{K} -tensor product, and hearkening back to proposition 1.14 expect it to be pivotal under the duality $V^* = V \multimap \mathbb{K}$.

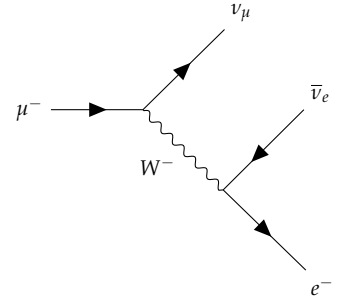

Figure 2.10: A Feynman diagram, which is read left-to-right rather than bottom-to-top.

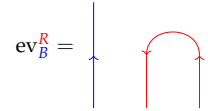

Figure 2.11: Constructing closed monoidal evaluation $\text{ev}_B^R : (R \multimap B) \otimes R \rightarrow B$ from rigid evaluation.

⁴⁵ i.e. $C(X \otimes A, Y) \cong C(X, Y \otimes A^*)$ naturally in X and Y .

The evaluation $\text{ev}_V : V^* \otimes V \rightarrow \mathbb{K}$ is given by usual tensor contraction $f \otimes v \mapsto f(v)$, for which we fix the notation

$$\langle f, v \rangle := \text{ev}_V(f, v) = f(v).$$

To explicitly construct coevaluation, suppose $\{e_i\}_{i=1}^n$ is a basis for V and $\{e^i\}_{i=1}^n$ is a dual basis for V^* .⁴⁶ Then coevaluation corresponds to the element

$$\sum_{i=1}^n e_i \otimes e^i \in V \otimes V^* \tag{2.8}$$

for which the zigzag identities are easily verified.⁴⁷ By virtue of proposition 2.32 we can view this as the image of the identity on V under the isomorphism $V \dashv\dashv V \cong V \otimes V^*$. Note that the finite dimensionality of V is crucial for this definition to even make sense, since otherwise eq. (2.8) is an infinite sum.

The pivotal nature of $\text{Vect}_{(\mathbb{K})}$ enriches the formal duality of its monoids and comonoids. Since $?^* : \mathcal{C} \rightarrow \mathcal{C}^{\text{op}}$ is a monoidal functor,⁴⁸ it maps monoids to comonoids and vice versa, thus inducing an equivalence of categories $\text{Mon}_{(\mathbb{K})} \simeq \text{Comon}_{(\mathbb{K})}$. In particular, the dual H^* of a \mathbb{K} -bimonoid H is also a \mathbb{K} -bimonoid, called the **dual \mathbb{K} -bimonoid**, and if H is a Hopf \mathbb{K} -algebra with antipous σ then H^* is a Hopf \mathbb{K} -algebra with antipous σ^* .⁴⁹

AS USEFUL AS string diagrams are, we will occasionally need symbolic notation for comultiplication in a \mathbb{K} -comonoid X . A convenient notation is due to Sweedler.⁵⁰ This begins with the observation that there exists some (usually non-unique) choice of simple tensors $x_{1,i} \otimes x_{2,i}$ such that

$$\sum_{i=1}^n x_{1,i} \otimes x_{2,i} = \begin{array}{c} \diagup \quad \diagdown \\ \circ \\ \text{---} \\ \square \\ x \end{array}$$

and most things we do will not depend on this decomposition.⁵¹ Instead of invoking an actual decomposition, **Sweedler notation** mirrors the form of this expression and writes

$$\sum_{(x)} x_{(1)} \otimes x_{(2)} := \begin{array}{c} \diagup \quad \diagdown \\ \circ \\ \text{---} \\ \square \\ x \end{array}$$

and the same goes for iterated multiplications. We also fix the symbols $\Delta_n : X \rightarrow X^{\otimes n}$ for the n th iterated comultiplication and $\epsilon = \Delta_0 : X \rightarrow \mathbb{K}$ for the counit of a comonoid. In particular $\Delta := \Delta_2$.

Example 2.35. The antipous law, eq. (2.4), for a Hopf monoid H in Sweedler notation reads

$$\sum_{(x)} \sigma(x_{(1)})x_{(2)} = \epsilon(x)1 = \sum_{(x)} x_{(1)}\sigma(x_{(2)})$$

for any $x \in H$.

⁴⁶ Recall a **dual basis** is a basis satisfying $e^i(e_j) = \delta_j^i$, and such a basis always exists.

⁴⁷ That this definition is basis independent follows from the uniqueness of duals established in proposition 2.29.

⁴⁸ By virtue of symmetry we do not need to take the reversed monoidal category.

⁴⁹ The validity of all these constructions follows from $?^*$ being a monoidal functor, but the reader can easily convince themselves by drawing some string diagrams and then bending strings appropriately.

⁵⁰ Sweedler, *Hopf Algebras*, §1.2, pp. 10–11.

⁵¹ Specifically, any operation acting *multilinearly* on this expression will be independent of the choice of decomposition. The expression $\sum_{i=1}^n (x_{1,i} + x_{2,i})$, on the other hand, would not be.

A NONZERO \mathbb{K} -COMONOID X cannot have the diagonal map as its comultiplication, since this is not linear. It may so happen, however, that certain distinguished elements of X are diagonalized by comultiplication. We call an element $x \in X$ **grouplike** iff it is nonzero and

$$\begin{array}{c} \diagup \\ \diagdown \\ \circ \\ | \\ \boxed{x} \end{array} = \begin{array}{c} | \quad | \\ \boxed{x} \quad \boxed{x} \end{array} .$$

The set of grouplikes in X is denoted $\text{Gr}(X)$.⁵²

⁵² The reason for this terminology will be made clear by corollary 2.42

Proposition 2.36. *Let $g \in X$ be grouplike. Then $\epsilon(x) = 1$.*

Proof. Coünitality gives

$$\begin{array}{c} | \\ \boxed{g} \end{array} = \begin{array}{c} \diagup \\ \diagdown \\ \circ \\ | \\ \boxed{g} \end{array} = \begin{array}{c} \circ \\ | \\ \boxed{g} \end{array} \begin{array}{c} | \\ \boxed{g} \end{array}$$

whence the claimed equation. □

Proposition 2.37. *Let X be a \mathbb{K} -comonoid. Then $\text{Gr}(X)$ is a linearly independent set.*

Proof. For $|\text{Gr}(X)| \leq 1$ the statement is vacuously true, so consider the other case and let $g \in \text{Gr}(X)$. Suppose towards contradiction $g = \sum_{i=1}^m a_i g_i$ for some $a_i \in \mathbb{K}$ and linearly independent $g_i \in \text{Gr}(X) \setminus \{g\}$. Then on the one hand

$$\sum_{(g)} g_{(1)} \otimes g_{(2)} = g \otimes g = \sum_{i=1}^m \sum_{j=1}^m a_i a_j (g_i \otimes g_j)$$

and on the other

$$\sum_{(g)} g_{(1)} \otimes g_{(2)} = \sum_{i=1}^m a_i (g_i \otimes g_i).$$

Since $g_i \otimes g_j$ are linearly independent in $X \otimes X$, we have $a_i a_j = 0$ for $i \neq j$, and otherwise $a_i^2 = a_i$. Now for some i we have $a_i \neq 0$, whence $a_j = 0$ for any $j \neq i$, so there is a unique i such that $a_i \neq 0$, so

$$g \otimes g = a_i^2 (g_i \otimes g_i) = a_i (g_i \otimes g_i)$$

whence $a_i = 1$ and thus $g = g_i \in \text{Gr}(X) \setminus \{g\}$, a contradiction. Therefore $\text{Gr}(X)$ is a linearly independent set. □

⁵³ Underwood, *Fundamentals of Hopf Algebras*, proposition 1.2.18, pp. 18–19.

Proposition 2.38. *The image of a grouplike under a \mathbb{K} -comonoid morphism is a grouplike. Thus $\text{Gr} : \text{Comon}(\mathbb{K}) \rightarrow \text{FinSet}$ is a functor.*

Proof. For any \mathbb{K} -comonoid morphism $f : R \rightarrow B$ and grouplike $g \in \text{Gr}(R)$,

$$\begin{array}{c} \diagup \\ \diagdown \\ \circ \\ | \\ \boxed{f} \\ | \\ \boxed{g} \end{array} = \begin{array}{c} | \quad | \\ \boxed{f} \quad \boxed{f} \\ \diagdown \quad \diagup \\ \circ \\ | \\ \boxed{g} \end{array} = \begin{array}{c} | \quad | \\ \boxed{f} \quad \boxed{f} \\ | \quad | \\ \boxed{g} \quad \boxed{g} \end{array} .$$

as claimed. We can thus define $\text{Gr}(f) : \text{Gr}(R) \rightarrow \text{Gr}(B)$ as the restriction $f \upharpoonright \text{Gr}(R)$. \square

Since every set S carries a unique comonoid structure and the free vector space functor $\mathbb{K}^{(?)}$: $\text{FinSet} \rightarrow \text{Vect}_{(\mathbb{K})}$ is monoidal, free vector spaces have a natural \mathbb{K} -comonoid structure in which basis elements are diagonal. For reasons which will become apparent later, we denote the **free \mathbb{K} -comonoid** as $\mathbb{K}S$.

Proposition 2.39. *We have an adjunction $\mathbb{K}^{(?)} \dashv \text{Gr} : \text{Comon}_{(\mathbb{K})} \rightarrow \text{FinSet}$.⁵⁴*

Proof. Let X be a finite set. Note the inclusion of X in $\mathbb{K}X$ induces a natural bijection $\iota_X : X \rightarrow \text{Gr}(\mathbb{K}X)$.⁵⁵ We show this is a unit of adjunction, that is for any space $Y \in \text{Vect}_{(\mathbb{K})}$ and appropriate function f there is a unique adjunct f^\sharp such that

$$\begin{array}{ccc}
 \mathbb{K}X & & \text{Gr}(\mathbb{K}X) \xleftarrow{\iota_X} X \\
 \exists! f^\sharp \downarrow & & \downarrow \text{Gr}(f^\sharp) \\
 Y & & \text{Gr}(Y)
 \end{array}$$

(Note: A diagonal arrow labeled f also points from X to $\text{Gr}(Y)$)

commutes. Since $\mathbb{K}X$ is spanned by grouplikes, the \mathbb{K} -linear map f^\sharp is uniquely determined by $f^\sharp(x) = f(x)$ for any $x \in X$. \square

Lemma 2.40. *Let H be a \mathbb{K} -bimonoid. Then $\text{Gr}(H)$ is a monoid under the multiplication of H .*

Proof. H is a monoid as a set, we show that $\text{Gr}(H)$ is a submonoid thereof. Recalling the definition of a bimonoid, we have

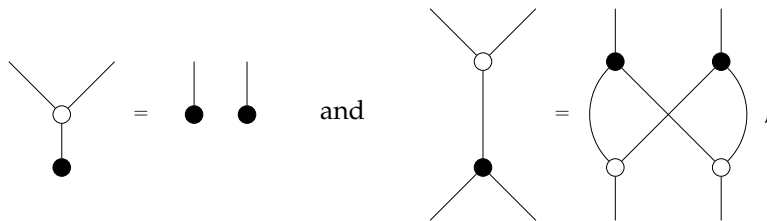

from which it immediately follows that the unit is grouplike and the product of grouplikes is grouplike. \square

Proposition 2.41. *Let H be a Hopf \mathbb{K} -algebra and $g \in H$ be grouplike. Then $\sigma(g) = g^{-1}$, i.e. $\sigma(g)g = 1 = g\sigma(g)$.*

Proof. From the antipous law and proposition 2.36 we have

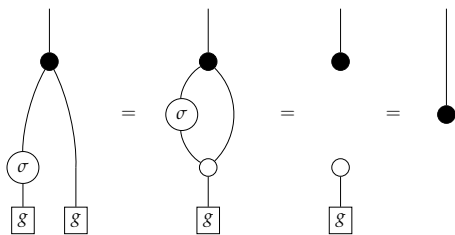

as required. \square

⁵⁴ Gr is not only a left adjoint but also an essential postinverse to the free functor $\mathbb{K}^{(?)}$, since ι gives an equivalence $\text{Gr}(\mathbb{K}^{(?)}) \simeq 1$.
⁵⁵ This is surjective by proposition 2.37: Since the elements of X span $\mathbb{K}X$ and are all grouplike, they must form the complete set $\text{Gr}(\mathbb{K}X)$.

Corollary 2.42. *Let H be a Hopf \mathbb{K} -algebra. Then $\text{Gr}(H)$ is a group under the multiplication of H .*

Mirroring our discussion for plain sets and free comonoids, a finite group G is the same as a Hopf monoid in FinSet , and therefore applying the monoidal free functor delivers a Hopf \mathbb{K} -algebra called the **group algebra** $\mathbb{K}G$. This is a *linearized* version of the structure of G . Its elements are formal linear combinations of group elements, its multiplication is induced from that of group elements, its counit evaluates group elements to one, and its comultiplication diagonalizes group elements.

Proposition 2.43. *We have an adjunction $\mathbb{K}^? \dashv \text{Gr} : \text{Hopf}_{(\mathbb{K})} \rightarrow \text{FinGrp}$.*

Proof. The adjunction is identical to that of proposition 2.39, we only need to check the construction makes sense in these categories. Given a group X , we see that $\iota_X : X \rightarrow \text{Gr}(X)$ is an isomorphism of groups. We also see that if Y is a Hopf \mathbb{K} -algebra and $f : X \rightarrow \text{Gr}(X)$ is a group homomorphism, then f^\sharp as defined is a Hopf algebra morphism. This completes the proof. \square

The group algebra $\mathbb{K}G$ is often defined with only its \mathbb{K} -monoid structure, and in this form $\mathbb{K}^?$ is a left adjoint to the *group of units* functor $?^\times$. A drawback of this approach is that the functor $\mathbb{K}^? : \text{FinGrp} \rightarrow \text{Mon}_{(\mathbb{K})}$ is not lossless: There are nonisomorphic groups with isomorphic group algebras.⁵⁶ On the other hand, we can recover a group from its (Hopf) group algebra by taking the group of grouplikes.

It follows that group algebras are precisely those Hopf algebras spanned by their grouplikes. It is straightforward to verify that for any Hopf \mathbb{K} -algebra H , any subalgebra generated by grouplikes is such a group algebra, and the counit $\epsilon_H : \mathbb{K}\text{Gr}(H) \rightarrow H$ of the adjunction in proposition 2.43 is the inclusion of the maximal group subalgebra of H .

The following result implies all finite-dimensional Hopf \mathbb{K} -algebras are autonomous.

Theorem 2.44 (Radford). *Let H be a finite-dimensional Hopf \mathbb{K} -algebra with antipode σ . Then σ has finite order, i.e. there exists a positive $n \in \mathbb{N}$ for which $\sigma^n = 1_H$.⁵⁷*

2.12 Ideals

In order to construct quotient Hopf \mathbb{K} -algebras, we will need to extend the concept of the **ideal** familiar from ring theory:

Definition 2.45. Let \mathcal{A} be a \mathbb{K} -monoid with multiplication $\mu : \mathcal{A} \otimes \mathcal{A} \rightarrow \mathcal{A}$. An **ideal** is a subspace $I \leq_{\mathbb{K}} \mathcal{A}$ such that $\mu(I \otimes \mathcal{A} + \mathcal{A} \otimes I) \subseteq I$.

It is straightforward to verify that the kernel of any \mathbb{K} -monoid morphism is an ideal.⁵⁸ Given an ideal I of \mathcal{A} , we can construct a

⁵⁶ This is even true for the integral group algebra $\mathbb{Z}G$ with knowledge of the counit retained, see Hertweck, “A Counterexample to the Isomorphism Problem for Integral Group Rings.”

⁵⁷ Radford, “The Order of the Antipode of a Finite Dimensional Hopf Algebra Is Finite.”

⁵⁸ If $x \in \ker f$ and $y \in \mathcal{A}$, then $f(xy) = f(x)f(y) = 0 = f(y)f(x) = f(yx)$.

quotient \mathbb{K} -monoid \mathcal{A}/I with multiplication $(x + I)(y + I) = xy + I$ and unit $1 + I$, so that the canonical projection $\pi : \mathcal{A} \twoheadrightarrow \mathcal{A}/I$ is a \mathbb{K} -monoid morphism with $\ker \pi = I$.

The reason for presenting definition 2.45 in a slightly alien way is to motivate the dual concept:

Definition 2.46. Let \mathcal{C} be a \mathbb{K} -comonoid with comultiplication $\Delta : \mathcal{C} \rightarrow \mathcal{C} \otimes \mathcal{C}$. A **coideal** is a subspace $I \leq_{\mathbb{K}} \mathcal{C}$ such that $\Delta(I) \subseteq I \otimes \mathcal{C} + \mathcal{C} \otimes I$ and $\epsilon(I) = 0$.

One can verify that the kernel of any \mathbb{K} -comonoid comorphism is a coideal.⁵⁹ Given a coideal I of \mathcal{C} , we can construct a **quotient \mathbb{K} -comonoid \mathcal{C}/I** with comultiplication $\Delta(x + I) = \sum_{(x)} (x_{(1)} + I)(x_{(2)} + I)$ and counit $\epsilon(x + I) = \epsilon(x)$, so that the canonical projection $\pi : \mathcal{C} \twoheadrightarrow \mathcal{C}/I$ is a \mathbb{K} -comonoid morphism with $\ker \pi = I$.

There is another useful way of characterizing coideals in terms of the more familiar structure of the dual \mathbb{K} -monoid \mathcal{C}^* . For a set of vectors $S \subseteq V$, we denote the **orthogonal complement**

$$S^\perp = \{f \in V^* : \langle f, S \rangle = 0\} \leq_{\mathbb{K}} V^*.$$

Proposition 2.47. Let $X \leq_{\mathbb{K}} V$ and $Y \leq_{\mathbb{K}} W$ for finite-dimensional \mathbb{K} -vector spaces V, W . Then $(X^\perp)^\perp = X$ and $(X \otimes Y)^\perp = X^\perp \otimes W^* + V^* \otimes Y^\perp$.

Proof. Let $v \in V$ such that $\langle X^\perp, v \rangle = 0$. Suppose towards contradiction $v \notin X$. Then there exists $Z \leq_{\mathbb{K}} V$ such that $V = X \oplus \mathbb{K}v \oplus Z$, and we can define an $f \in V^*$ such that $f(v) = 1$ and $f(X \oplus Z) = 0$. Then $f \in X^\perp$ but $\langle f, v \rangle = 1$, a contradiction. Therefore $(X^\perp)^\perp = X$.

Taking the duals of the inclusions $\iota_X : X \hookrightarrow V$ and $\iota_Y : Y \hookrightarrow W$ gives maps $\iota_X^* : V^* \twoheadrightarrow X^*$ and $\iota_Y^* : W^* \twoheadrightarrow Y^*$, and we have $\ker \iota_X^* = X^\perp$ and $\ker \iota_Y^* = Y^\perp$.⁶⁰ Thus ι_X^* and ι_Y^* factorize via quotients so that

$$\begin{array}{ccc} V^* & \xrightarrow{\iota_X^*} & X^* \\ \searrow \pi_1 & & \nearrow j_1 \\ & V^*/X^\perp & \end{array} \qquad \begin{array}{ccc} W^* & \xrightarrow{\iota_Y^*} & Y^* \\ \searrow \pi_2 & & \nearrow j_2 \\ & W^*/Y^\perp & \end{array}$$

commute for some \mathbb{K} -linear monomorphisms j_1, j_2 . On the other hand the inclusion $\iota_{X \otimes Y} : X \otimes Y \hookrightarrow V \otimes W$ has a dual $\iota_{X \otimes Y}^* : V^* \otimes W^* \twoheadrightarrow X^* \otimes Y^*$ with kernel $(X \otimes Y)^\perp$. Since

$$\begin{array}{ccc} V^* \otimes W^* & \xrightarrow{\iota_{X \otimes Y}^*} & X^* \otimes Y^* \\ \searrow \pi_1 \otimes \pi_2 & & \nearrow j_1 \otimes j_2 \\ & (V^*/X^\perp) \otimes (W^*/Y^\perp) & \end{array}$$

commutes, it follows

$$(X \otimes Y)^\perp = \ker \iota_{X \otimes Y}^* = \ker(\pi_1 \otimes \pi_2) = X^\perp \otimes W^* + V^* \otimes Y^\perp$$

as required.⁶¹

⁵⁹ Let $f : \mathcal{C} \rightarrow \mathcal{C}'$ be a \mathbb{K} -comonoid morphism. First, note $\epsilon(\ker f) = \epsilon f(\ker f) = 0$. Second, note that $\Delta \circ f = (f \otimes f) \circ \Delta$, so $\Delta(\ker f) \subseteq \ker(f \otimes f) = (\ker f) \otimes \mathcal{C} + \mathcal{C} \otimes (\ker f)$.

⁶⁰ Explicitly, for $v^* \in V^*$ and $x \in X$ we have $\langle \iota_X^*(v^*), x \rangle = \langle v^*, x \rangle$, whence the claimed characterization of X^\perp follows.

□

⁶¹ Sweedler, *Hopf Algebras*, propositions A.1, A.4, pp. 317–20.

Proposition 2.48. *Let \mathcal{C} be a \mathbb{K} -comonoid. Then $I \leq_{\mathbb{K}} \mathcal{C}$ is a coideal iff I^{\perp} is a \mathbb{K} -submonoid of \mathcal{C}^* .*

Proof. Suppose I is a coideal of \mathcal{C} . Since $\epsilon(I) = 0$, it follows that ϵ^* , the unit of \mathcal{C}^* , is in I^{\perp} . To show I^{\perp} is closed under multiplication we must show $\Delta^*(I^{\perp} \otimes I^{\perp}) \subseteq I^{\perp}$, or what is the same,

$$0 = \langle \Delta^*(I^{\perp} \otimes I^{\perp}), I \rangle = \langle I^{\perp} \otimes I^{\perp}, \Delta(I) \rangle.$$

But since I is a coideal,

$$\langle I^{\perp} \otimes I^{\perp}, \Delta(I) \rangle \subseteq \langle I^{\perp} \otimes I^{\perp}, I \otimes \mathcal{C} \rangle + \langle I^{\perp} \otimes I^{\perp}, \mathcal{C} \otimes I \rangle = 0$$

wherefore I^{\perp} is a \mathbb{K} -submonoid.

For the converse, suppose I^{\perp} is a \mathbb{K} -submonoid of \mathcal{C}^* . Then $\epsilon^* \in I^{\perp}$ and thus $\epsilon(I) = 0$. We must also have $\Delta^*(I^{\perp} \otimes I^{\perp}) = I^{\perp}$. whence

$$\langle I^{\perp} \otimes I^{\perp}, \Delta(I) \rangle = \langle \Delta^*(I^{\perp} \otimes I^{\perp}), I \rangle = \langle I^{\perp}, I \rangle = 0$$

so $\Delta(I) \subseteq (I^{\perp} \otimes I^{\perp})^{\perp} = I \otimes \mathcal{C} + \mathcal{C} \otimes I$ by proposition 2.47 as required.⁶² □

⁶² Sweedler, proposition 1.4.6, pp. 19–22.

A **biideal** I of a \mathbb{K} -bimonoid \mathcal{B} is at once an ideal and coideal. From the discussion for ideals and coideals, the kernel of any \mathbb{K} -bimonoid morphism must be a biideal, and given a biideal I of \mathcal{B} we can form the **quotient \mathbb{K} -bimonoid**. A **Hopf ideal** I of a Hopf algebra \mathcal{H} is a biideal stable under the antipous, in the sense that $\sigma(I) \leq_{\mathbb{K}} I$. It follows from proposition 2.24 that kernels of Hopf \mathbb{K} -algebra morphisms have this property, and given a Hopf ideal I of \mathcal{H} we can form the **quotient Hopf \mathbb{K} -algebra** \mathcal{H}/I with antipous $\sigma(x + I) = \sigma(x) + I$.

2.13 A menagerie of Hopf algebras

Definition 2.49. Let V be a \mathbb{K} -vector space. As a vector space, **tensor algebra** $T(V)$ is the direct sum

$$T(V) = \bigoplus_{i=0}^{\infty} T^i V$$

where $T^0 V = \mathbb{K}$ and $T^i V = V^{\otimes i}$. This becomes a Hopf algebra where the product is the tensor product,⁶³ the unit is $1 \in T^0 V$, the counit is defined by $\epsilon(V) = 0$, the comultiplication is defined by $\Delta(v) = 1 \otimes v + v \otimes 1$ for $v \in V$, and the antipous by $\sigma(v) = -v$ for $v \in V$.

⁶³ We will write this “internal” tensor product by juxtaposition. Some care needs to be taken with expressions like $1 \otimes v + v \otimes 1$, since this is an element of $T(V) \otimes T(V)$ and *not* $T^2 V$.

An element $v \in A$ of a \mathbb{K} -bimonoid \mathcal{A} which comultiplies as $\Delta(v) = 1 \otimes v + v \otimes 1$ is called **primitive**.

Definition 2.50. A **Lie \mathbb{K} -algebra** \mathfrak{g} is a nonassociative \mathbb{K} -algebra with an alternating product

$$[\cdot, \cdot] : \mathfrak{g} \otimes \mathfrak{g} \rightarrow \mathfrak{g}$$

called the (Lie) **bracket**, satisfying the **Jacobi identity**

$$0 = [x, [y, z]] + [y, [z, x]] + [z, [x, y]]$$

for all $x, y, z \in \mathfrak{g}$. A subspace $\mathfrak{a} \leq_{\mathbb{K}} \mathfrak{g}$ closed under the bracket is also a Lie algebra, called a **Lie subalgebra**.

Example 2.51. Let A be a \mathbb{K} -monoid. Then A is a Lie \mathbb{K} -algebra under the **commutator** $[x, y] = xy - yx$. In particular, the Lie algebra obtained from $\text{End}_{\mathbb{K}} V$ in this way is denoted $\mathfrak{gl}(V)$.

Example 2.52. Let A be a \mathbb{K} -algebra. A derivation $D \in \text{End}_{\mathbb{K}}(A)$ is a linear endomorphism satisfying the **Leibniz rule**

$$D(ab) = (Da)b + a(Db)$$

for any $a, b \in A$. The set of all derivations $\text{der}(A)$ is a Lie subalgebra of $\text{End}_{\mathbb{K}}(A)$, which we call the **derivation subalgebra**.⁶⁴

⁶⁴ Etingof et al., *Introduction to Representation Theory*, §2.9, p. 22.

Proposition 2.53. Let \mathfrak{g} be a Lie algebra and $T(\mathfrak{g})$ be its tensor algebra. Let $I_0 = \{xy - yx - [x, y] : x, y \in \mathfrak{g}\}$. The ideal I generated by I_0 is a Hopf ideal.

Proof. Clearly $\epsilon(I) = 0$ and $\sigma(I) = I$. For $x, y \in \mathfrak{g}$ first note

$$\begin{aligned} \Delta(xy) &= (1 \otimes x + x \otimes 1)(1 \otimes y)(y \otimes 1) \\ &= 1 \otimes xy + xy \otimes 1 + x \otimes 1 + 1 \otimes y \end{aligned}$$

and thus

$$\Delta(xy - yx - [x, y]) = 1 \otimes (xy - yx - [x, y]) + (xy - yx - [x, y]) \otimes 1$$

so all elements of I_0 are primitive. For $z \in T(\mathfrak{g})$ and $x \in I_0$, we have

$$\begin{aligned} \Delta(zx) &= \sum_{(z)} (z_{(1)} \otimes z_{(2)})(1 \otimes x + x \otimes 1) \\ &= \sum_{(z)} z_{(1)} \otimes z_{(2)}x + \sum_{(z)} z_{(1)}x \otimes z_{(2)} \end{aligned}$$

so $\Delta(T(\mathfrak{g})I_0) \leq_{\mathbb{K}} T(\mathfrak{g}) \otimes I + I \otimes T(\mathfrak{g})$, and a similar argument shows $\Delta(I_0T(\mathfrak{g})) \leq_{\mathbb{K}} T(\mathfrak{g}) \otimes I + I \otimes T(\mathfrak{g})$. Therefore $\Delta(I) \leq_{\mathbb{K}} T(\mathfrak{g}) \otimes I + I \otimes T(\mathfrak{g})$ and I is a Hopf ideal. \square

Definition 2.54. Let \mathfrak{g} be a Lie algebra and I be as in proposition 2.53. The **universal enveloping algebra** is $T(\mathfrak{g})/I$.⁶⁵

⁶⁵ The universal enveloping algebra plays a role in the representation theory of Lie algebras analogous to that of the group algebra in the representation theory of groups, which we explore in detail in §3. The notions of $U(\mathfrak{g})$ -module and representation of \mathfrak{g} may be used interchangeably.

Definition 2.55. Let G be a finite group. The **algebra of functions** \mathbb{K}^G is a Hopf \mathbb{K} -algebra with pointwise multiplication, the constant function $1 : G \rightarrow \mathbb{K}$ as the unit, the comultiplication $\Delta : \mathbb{K}^G \rightarrow \mathbb{K}^G \otimes \mathbb{K}^G \cong \mathbb{K}^{G \times G}$ defined by $(\Delta f)(x, y) = f(xy)$ for $x, y \in G$, the counit $\epsilon : \mathbb{K}^G \rightarrow \mathbb{K}$ defined by $\epsilon(f) = f(1)$, and the antipode defined by $(\sigma f)(x) = f(x^{-1})$ for $x \in G$.

Proposition 2.56. $\mathbb{K}G$ and \mathbb{K}^G are dual Hopf \mathbb{K} -algebras, i.e. we have a natural equivalence $(\mathbb{K}?)^* \simeq \mathbb{K}^? : \text{Grp}^{\text{op}} \rightarrow \text{Hopf}_{\mathbb{K}}$.

Proof. We construct a natural isomorphism $\eta : (\mathbb{K}?)^* \Rightarrow \mathbb{K}^? : \text{Grp}^{\text{op}} \rightarrow \text{Hopf}_{\mathbb{K}}$. The group algebra $\mathbb{K}G$ is equipped with a natural set inclusion $\iota_G : G \hookrightarrow \mathbb{K}G$.⁶⁶ As a function, we define η_G as the pullback $\iota_G^* = \text{Set}(\eta_G, \mathbb{K}) : (\mathbb{K}G)^* \rightarrow \mathbb{K}^G$. Naturality of $\eta : (\mathbb{K}?) \Rightarrow \mathbb{K}^? : \text{Grp}^{\text{op}} \rightarrow \text{Set}$ then follows from it being the functorial image of a natural transformation. For every function $f : G \rightarrow \mathbb{K}$ let $\bar{f} : \mathbb{K}G \rightarrow \mathbb{K}$ denote its linear extension. Then $f \mapsto \bar{f}$ is a two-sided inverse of η_G , showing the latter to be bijective. For clarity we will also denote $\bar{x} = \iota_G(x)$, so in particular $\bar{1}$ is the unit of $\mathbb{K}G$.

It remains to show that $\eta_G : (\mathbb{K}G)^* \rightarrow \mathbb{K}^G$ is a morphism of Hopf \mathbb{K} -algebras for any group G . Let $f, g \in \mathbb{K}^G$, $a, b \in \mathbb{K}$, and $\mu : \mathbb{K}G \otimes \mathbb{K}G \rightarrow \mathbb{K}G$ denote the multiplication of $\mathbb{K}G$. For \mathbb{K} -linearity, note $\eta_G(a\bar{f} + b\bar{g})(x) = a\bar{f}(\bar{x}) + b\bar{g}(\bar{x}) = f(x) + g(x)$. For unitality, note $\eta_G(\epsilon^*) = 1 \in \mathbb{K}^G$ by definition of the counit of $\mathbb{K}G$. Since $\eta_G(\Delta^*(\bar{f} \otimes \bar{g}))(x) = \bar{f}(\bar{x})\bar{g}(\bar{x}) = f(x)g(x)$, it follows η_G is a \mathbb{K} -monoid morphism. For counitality, note $f(1) = \bar{f}(\bar{1}) = \bar{1}^*(\bar{f}) = \bar{1}^*\eta_G(f)$. Since $\Delta f(x, y) = f(xy) = \bar{f}\mu(\bar{x} \otimes \bar{y}) = \mu^*(\bar{f})(\bar{x} \otimes \bar{y}) = (\eta_G \otimes \eta_G)\mu^*(f)(x, y)$, it follows η_G is a \mathbb{K} -comonoid morphism. Therefore, η_G is a natural isomorphism of Hopf \mathbb{K} -algebras. \square

The examples discussed thus far are *classical*, in that they are all either commutative or cocommutative, and thus by proposition 2.26 are all involutive. The following is neither commutative nor cocommutative, and has an antipous of large order.

Definition 2.57. Let \mathbb{K} be algebraically closed, $n \geq 2$ be an integer, and $q \in \mathbb{K}$ be a primitive n th root of unity. The **Drinfel'd double**⁶⁷ \mathcal{D}_n of the **Taft algebra** \mathcal{H}_n is an n^4 -dimensional Hopf \mathbb{K} -algebra generated as a \mathbb{K} -monoid by a, b, c, d such that

$$\begin{aligned} ba &= qab, & db &= qbd, & ca &= qac, & dc &= qcd, \\ bc &= cb, & da - qad &= 1 - bc, & a^n &= 0 = d^n, & b^n &= 1 = c^n \end{aligned}$$

with coproduct and counit

$$\begin{aligned} \Delta(a) &= a \otimes b + 1 \otimes a, & \Delta(d) &= d \otimes c + 1 \otimes d, \\ \Delta(b) &= b \otimes b, & \Delta(c) &= c \otimes c, \\ \epsilon(a) &= 0 = \epsilon(d), & \epsilon(b) &= 1 = \epsilon(c), \end{aligned}$$

and antipous

$$\sigma(a) = -ab^{-1}, \quad \sigma(b) = b^{-1}, \quad \sigma(c) = c^{-1}, \quad \sigma(d) = -dc^{-1}$$

where the n^2 -dimensional subalgebra generated by a and b is the Taft algebra \mathcal{H}_n .⁶⁸

Since the comultiplication is an \mathbb{K} -monoid morphism, it follows that the elements $b^i c^j$ for $0 \leq i, j \leq n-1$ are grouplike and thus form a basis for a group subalgebra.

Proposition 2.58. *The antipous of \mathcal{D}_n has order $2n$.*

Proof. By direct computation, $\sigma^2(a) = qa$, $\sigma^2(b) = b$, $\sigma^2(c) = c$, and $\sigma^2(d) = q^{-1}d$, whence the conclusion follows. \square

⁶⁶ The natural inclusion $\iota : 1 \Rightarrow \mathbb{K}^? : \text{Grp} \rightarrow \text{Set}$ is just the unit of adjunction for the free vector space functor.

⁶⁷ The *Drinfel'd double* of a Hopf algebra \mathcal{H} , also called the *quantum double*, is a general recipe for constructing a so-called *quasitriangular Hopf algebra* which containing \mathcal{H} as a Hopf subalgebra. We will not go into the general construction here, instead defining this particular example explicitly via generators and relations. For a modern treatment using string diagrams see Kashaev, "The Quantum Double."

⁶⁸ Chen, "A Class of Noncommutative and Noncocommutative Hopf Algebras"; Benkart et al., "McKay Matrices for Finite-Dimensional Hopf Algebras."

3

Representation theory

Representation theory traces the following general pattern: We have some structure, say a *gadget* \mathcal{G} , which we study by seeking an analogous structure on \mathbb{K} -vector spaces¹ — a \mathbb{K} -representation of \mathcal{G} .

The original context for representation theory is the representation theory of finite groups. This work was initiated by German mathematician F. G. Frobenius in 1896 after he received a letter from R. Dedekind with an interesting observation relating the degrees of group elements to factorizations of determinants of certain matrices. Dedekind was unable to prove this connection held in general. Out of Frobenius's successful efforts to prove what Dedekind could not, the representation theory of finite groups was born.²

Initially representation theory was regarded with scepticism by the mathematical establishment as a neat but frivolous toy. The 1897 edition of Burnside's *Theory of Groups* was devoid of linear representations, which he justified saying "it would be difficult to find a result that could be most directly obtained by the consideration of groups of linear transformations." It soon became clear, however, that this attitude was wrong, and the theory of representations had much to offer not just to number theory but also to the study of the structure of finite groups.³ A wholesale attitude reversal is apparent in the second edition of Burnside's book, published in 1911, whose preface began

Very considerable advances in the theory of groups of finite order have been made since the appearance of the first edition of this book. In particular the theory of groups of linear substitutions has been the subject of numerous and important investigations by several writers; and the reason given in the original preface for omitting any account of it no longer holds good. In fact it is now more true to say that for further advances in the abstract theory one must look largely to the representation of a group as a group of linear substitutions.⁴

IN ITS ORIGINAL SENSE, a representation of a group is a group homomorphism from G to a group of \mathbb{K} -linear transformations. A modern perspective brings two alternate points of view: A group representation is a functor from the group-as-category \underline{G} to the category $\text{Vect}_{(\mathbb{K})}$; or a module over the group algebra $\mathbb{K}G$. Both category theory and the theory of modules over a monoid may

¹ In this work the *carrier spaces* of representations will always be finite-dimensional, though definitions are easily generalized.

² Etingof et al., *Introduction to Representation Theory*, §1, p. 1.

³ Curtis, *Pioneers of Representation Theory*, §III.1, p. 90.

⁴ Burnside, *Theory of Groups of Finite Order*, p. v.

thus be viewed as generalizations of representation theory, and depending on the nature of the *gadgets* being studied, both may prove useful. This chapter will mainly develop the module theoretic approach.

Still, of all algebraic objects, finite groups admit perhaps the nicest representation theory, by virtue of a number of “miracles” we will review in §3.1. Second place probably goes to their continuous counterpart — compact Lie groups — and the closely related representation theory of Lie algebras. From a module theoretic standpoint, it makes sense to ask what these structures (or rather, the corresponding \mathbb{K} -monoids) have in common which gives rise to this nice representation theory. As the reader might guess, a large part of this structure comes down to that of a Hopf algebra. The formal setting for this is *Tannaka duality*, which investigates the interplay between properties of an object and its category of modules.

In this chapter, G denotes a finite group, \mathcal{A} a finite-dimensional \mathbb{K} -monoid, and \mathcal{H} a finite-dimensional Hopf \mathbb{K} -algebra. Unadorned tensor products denote the \mathbb{K} -tensor product, i.e. $V \otimes W := V \otimes_{\mathbb{K}} W$, and $\dim V := \dim_{\mathbb{K}} V$.

3.1 Representations of groups

The natural way to conceptualize a group is to make it *act* on some object via automorphisms, giving rise to the concept of *group actions*. A good candidate for such an object is a \mathbb{K} -vector space, since these are particularly well understood.

Definition 3.1. A \mathbb{K} -**representation** of G is a group homomorphism $\rho_V : G \rightarrow \text{GL}(V)$ where V is a (finite dimensional) \mathbb{K} -vector space called the **carrier space**.

Example 3.2. Consider the symmetric group S_n acting on \mathbb{K}^n by permuting coördinates. This corresponds to a homomorphism $\rho : S_n \rightarrow \text{GL}_n(\mathbb{K})$ to permutation matrices.⁵ The restriction of ρ for any permutation group $G \leq S_n$ also forms a representation, called a **permutation representation**.

Example 3.3. For any G , we can define the **trivial representation** on \mathbb{K}^n by $\rho_{\mathbb{K}^n}(g) = 1$ for all $g \in G$. When we refer to \mathbb{K}^n as a representation without specifying the action, it is with this structure. In particular, \mathbb{K} is called the **trivial module**.

As a category, $\underline{\text{GL}}(V)$ embeds into $\text{Vect}_{\mathbb{K}}$, enabling the alternate definition

Definition 3.4. A \mathbb{K} -**representation** of G is a functor $\rho_V : \underline{G} \rightarrow \text{Vect}_{\mathbb{K}}$.

We call the representation ρ_V **faithful** iff it is faithful as a functor. Hence the representations given in example 3.2 are faithful.

Now ρ_V may be extended linearly to a *representation of the group*

⁵ For example, for $n = 3$ we have

$$\begin{aligned} \rho(1) &= \begin{bmatrix} 1 & 0 & 0 \\ 0 & 1 & 0 \\ 0 & 0 & 1 \end{bmatrix}, & \rho((123)) &= \begin{bmatrix} 0 & 0 & 1 \\ 1 & 0 & 0 \\ 0 & 1 & 0 \end{bmatrix}, \\ \rho((132)) &= \begin{bmatrix} 0 & 1 & 0 \\ 0 & 0 & 1 \\ 1 & 0 & 0 \end{bmatrix}, & \rho((12)) &= \begin{bmatrix} 0 & 1 & 0 \\ 1 & 0 & 0 \\ 0 & 0 & 1 \end{bmatrix}, \\ \rho((23)) &= \begin{bmatrix} 1 & 0 & 0 \\ 0 & 0 & 1 \\ 0 & 1 & 0 \end{bmatrix}, & \rho((13)) &= \begin{bmatrix} 0 & 0 & 1 \\ 0 & 1 & 0 \\ 1 & 0 & 0 \end{bmatrix}. \end{aligned}$$

algebra $\rho_V : \mathbb{K}G \rightarrow \text{End}_{\mathbb{K}}(V)$, whence for $u, v \in V$ and $g, h \in \mathbb{K}[G]$

$$\begin{aligned} \rho_V(1)v &= v, & \rho_V(gh)v &= \rho_V(g)\rho_V(h)v, \\ \rho_V(g)(u+v) &= \rho_V(g)u + \rho_V(g)v, & \rho_V(g+h)u &= \rho_V(g)u + \rho_V(h)u, \end{aligned}$$

so the action of $\mathbb{K}G$ on V induced by ρ_V makes V a $\mathbb{K}G$ -module. Likewise, if V is a $\mathbb{K}G$ module,⁶ then the embedding of $G \hookrightarrow \mathbb{K}G$ gives a representation of G in the above sense. Hence:

Definition 3.5. A \mathbb{K} -representation of a group G is a $\mathbb{K}G$ -module.

In order to emphasize the unifying role of Hopf algebras in the sequel, the discussion in this section will mostly ignore the full Hopf algebra structure of $\mathbb{K}G$, instead regarding it as a $\mathbb{K}G$ -monoid.

These equivalent definitions give rise to equivalent notions of a morphism $T : V \rightarrow W$ of representations. Thinking of representations as group homomorphisms as in definition 3.1, we think of T as an **intertwiner**, that is a linear transformation such that $T\rho_V(g) = \rho_W(g)T$ for all $g \in G$. When expressed as the commutative diagram in fig. 3.1, it is clear that this is the same as $T : \rho_V \Rightarrow \rho_W$ being a natural transformation between representations in the sense of definition 3.4. From this point of view the category of representations is $\text{Vect}_{(\mathbb{K})}^G$, which is easily shown to be equivalent to ${}_{(\mathbb{K}G)}\text{Mod}$.

Henceforth we use definitions 3.1, 3.4 and 3.5 interchangeably, for example we might say “ V is a \mathbb{K} -representation of G ” or “ ρ_V is a \mathbb{K} -representation of G ”, where the first is understood as referring to a $\mathbb{K}G$ -module V , and the latter refers to both the group homomorphism and functor ρ_V .

TO STUDY REPRESENTATIONS in general, it is expedient to study those which are “prime” or “atomic.” Module theory gives us two competing notions of primality. Recall that for a ring R , and submodule $U \leq_R V$ is a subset left invariant under the R -action of V . In particular, if R is a \mathbb{K} -monoid, then U will be a \mathbb{K} -vector subspace. We call U a subrepresentation of V precisely iff $U \leq_{\mathbb{K}G} V$, i.e. U is a G -invariant subspace. Then a module or representation is

- **irreducible** or **simple** iff it has no nonzero proper submodule;
- **completely reducible** or **semisimple** iff it is the direct sum of simple modules;
- **decomposable** iff it is the direct sum of two nonzero modules;
- **indecomposable** iff it is not decomposable.

It is clear that every simple module is indecomposable, but the converse is not true in general. A general finite-dimensional \mathbb{K} -monoid \mathcal{A} is called **semisimple** iff \mathcal{A} is semisimple as an \mathcal{A} -module,⁷ or equivalently every module in ${}_{(\mathcal{A})}\text{Mod}$ is semisimple.⁸ Thus our two primality notions coincide iff $\mathbb{K}G$ is semisimple. This is our first miracle:

⁶ And thus also a \mathbb{K} -vector space by proposition 2.19.

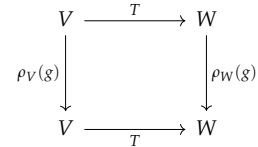

Figure 3.1: Commutative diagram for the intertwiner condition.

⁷ Surprisingly, whether \mathcal{A} is regarded as a left or right \mathcal{A} -module is inconsequential.

⁸ Etingof et al., *Introduction to Representation Theory*, proposition 3.5.8, p. 51.

Theorem 3.6 (Maschke's theorem). *Let G be a finite group. $\mathbb{K}G$ is semisimple iff $\text{char } \mathbb{K}$ does not divide $|G|$. Moreover, in this case,*

$$\mathbb{K}G \cong_{\mathbb{K}G} \bigoplus_{i=1}^t V_i^{\oplus \dim V_i}$$

where V_1, \dots, V_t contains exactly one representative of each isomorphism class of simple $\mathbb{K}G$ -modules.⁹

Corollary 3.7. *With the conditions of theorem 3.6, a $\mathbb{K}G$ -module is simple iff it is indecomposable.*

Outside of “nice” characteristic, the representation theory of finite groups is known as *modular representation theory*. In §3.2 we will develop a toolkit for dealing with modules over general \mathbb{K} -monoids where indecomposable and simple modules may not coincide.

ANOTHER NOTEWORTHY FEATURE of the representation theory of finite groups is that given two \mathbb{K} -representations U and V of G , there is a natural G -action on the tensor product vector space $U \otimes V$ by acting on each of the factors separately, so

$$\rho_{U \otimes V}(g) = \rho_U(g) \otimes \rho_V(g)$$

or as $\mathbb{K}G$ -modules,

$$g(u \otimes v) = gu \otimes gv.$$

It is straightforward to show that for any \mathbb{K} -representation V we have $V \cong_{\mathbb{K}G} \mathbb{K} \otimes V$.¹⁰ This not only makes the category $(\mathbb{K}G)\text{Mod}$ monoidal, but it does so in a way which is compatible with the monoidal structure of $\text{Vect}_{(\mathbb{K})}$.¹¹ We can formalize this with a forgetful **fibre functor** $F : (\mathbb{K}G)\text{Mod} \rightarrow \text{Vect}_{(\mathbb{K})}$ which takes each representation to its carrier space; the preceding argument shows that this functor is strict monoidal.

Now that we have shown $(\mathbb{K}G)\text{Mod}$ is monoidal, we can ask related questions introduced in §2, such as the existence of duals. By virtue of the fibre functor F , any rigid structure on $(\mathbb{K}G)\text{Mod}$ must be compatible with the pivotal structure on $\text{Vect}_{(\mathbb{K})}$, so the question becomes whether for a \mathbb{K} -representation V of G there is a natural G -action on the dual vector space $V^* = \text{Vect}_{(\mathbb{K})}(V, \mathbb{K})$. We can construct such an action as follows: For any $f \in V^*$ and $g \in G$, we define $gf \in V^*$ so that for any $v \in V$ we have

$$(gf)(v) = f(g^{-1}v)$$

or in terms of homomorphisms¹²

$$\rho_{V^*}(g) = \rho_V(g^{-1})^*.$$

This is known as the **dual representation** or **contragredient representation**.¹³

⁹ Etingof et al., *Introduction to Representation Theory*, §4.1, pp. 61–63.

¹⁰ As a reminder, we regard \mathbb{K} as carrying the trivial representation as in example 3.3.

¹¹ It is important to note that this monoidal structure on $(\mathbb{K}G)\text{Mod}$ is not an ordinary tensor product of $\mathbb{K}G$ -modules, which is not even a $\mathbb{K}G$ -module if G is non-abelian.

¹² The operation $?^* : \text{GL}(V) \rightarrow \text{GL}(V^*)$, which for matrices corresponds to the *transpose*, is induced by the duality $?^* : \text{End}_{\mathbb{K}}(V) \rightarrow \text{End}_{\mathbb{K}}(V^*)$ in $\text{Vect}_{(\mathbb{K})}$.

¹³ This is a representation since both $?^{-1}$ and $?^*$ reverse order of multiplication.

Lemma 3.8. Let $\{e_i\}_{i=1}^n$ and $\{e^i\}_{i=1}^n$ be dual \mathbb{K} -bases for a \mathbb{K} -representation V of G and its dual representation V^* . Then $\{ge_i\}_{i=1}^n$ and $\{ge^i\}_{i=1}^n$ are also dual bases for any $g \in G$.

Proof. That $\{ge_i\}_{i=1}^n$ and $\{ge^i\}_{i=1}^n$ are bases follows from the fact g acts as a \mathbb{K} -linear isomorphism. Since $ge^i(ge_j) = e^i(g^{-1}ge_j) = e^i(e_j) = \delta_j^i$, these are dual bases. \square

Proposition 3.9. Let V be a \mathbb{K} -representation of V and V^* be the dual representation. Then we have a duality $V \dashv V^*$ of $\mathbb{K}G$ -modules under the evaluation and coevaluation of $\text{Vect}(\mathbb{K})$.

Proof. We need to show that

$$\begin{aligned} \text{ev}_V : V \otimes V^* &\rightarrow \mathbb{K} \\ \text{coev}_V : \mathbb{K} &\rightarrow V^* \otimes V \end{aligned}$$

are $\mathbb{K}G$ -morphisms. Let $v \in V$, $f \in V^*$, and $a, b \in G$. Then

$$\begin{aligned} \text{ev}_V(ab(v \otimes f)) &= \text{ev}_V(abv \otimes abf) = (abf)(abv) \\ &= f(b^{-1}a^{-1}abv) = f(v) \\ &= ab f(v) = ab \text{ev}_V(v \otimes f) \end{aligned}$$

On the other hand, if $\{e_i\}_{i=1}^n$ and $\{e^i\}_{i=1}^n$ are dual bases for V and V^* respectively,

$$\begin{aligned} ab \text{coev}_V(1) &= ab \sum_{i=1}^n e^i \otimes e_i = \sum_{i=1}^n abe^i \otimes abe_i \\ &\stackrel{*}{=} \text{coev}_X(1) = \text{coev}_X(ab 1) \end{aligned}$$

where $(*)$ follows from lemma 3.8 and basis-independence of coevaluation. \square

In §3.3 we will see a more general argument demonstrating $(\mathbb{K}G)\text{Mod}$ is a pivotal category.

3.2 Representations of \mathbb{K} -monoids

Note that if \mathcal{A} is finite dimensional, V being finitely generated as an \mathcal{A} -module is the same as V being finite dimensional. It is straightforward to show that $(\mathcal{A})\text{Mod}$ has all the trappings of an abelian category as defined in definition A.1.

The representation theory of a semisimple \mathbb{K} -monoid \mathcal{A} can be viewed as degenerate. When simple and indecomposable \mathcal{A} -modules no longer coincide, many theorems such as theorem 3.6 split in two. An important role is played by a distinguished class of modules known as *projective*.

Definition 3.10. A finite-dimensional \mathcal{A} -module P is called **projective** iff any of the following equivalent conditions hold:

1. $(\mathcal{A})\text{Mod}(P, ?)$ preserves epimorphisms, i.e. for any R -morphism $f : P \rightarrow B$ and R -epimorphism $q : A \twoheadrightarrow B$ we have a lift $\bar{f} : P \rightarrow A$ so that fig. 3.2 commutes;

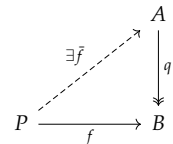

Figure 3.2: Lifting property of a projective module P .

2. Any module epimorphism $\alpha : A \rightarrow P$ splits;
3. P is a direct summand of a free module, i.e. $P \oplus Q \cong_{\mathcal{A}} \mathcal{A}^n$ for some module Q and $n \in \mathbb{N}_0$;
4. ${}_{(\mathcal{A})}\text{Mod}(P, ?)$ is exact.

Proof of equivalence. (1 \Rightarrow 2). Let $q : A \rightarrow P$ be an R -epimorphism. Then applying the lifting property in fig. 3.2 with $B = P$ and $f = 1_P$ gives a section \bar{f} of q , hence q is a split epimorphism.

(2 \Rightarrow 3). Since P is finitely generated, for some free module \mathcal{A}^n there exists an epimorphism $p : \mathcal{A}^n \rightarrow P$. Since the exact sequence

$$0 \rightarrow \ker p \hookrightarrow \mathcal{A}^n \rightarrow P \rightarrow 0$$

splits, we have the required direct sum decomposition.

(3 \Rightarrow 4). Clearly ${}_{(\mathcal{A})}\text{Mod}(\mathcal{A}, ?) \simeq 1$ is exact. Applying propositions A.2 and A.3 we see ${}_{(\mathcal{A})}\text{Mod}(\mathcal{A}^n, ?)$ is exact for any free module \mathcal{A}^n , and thus applying proposition A.3 once more we see ${}_{(\mathcal{A})}\text{Mod}(P, ?)$ must be exact for any projective module P .

(4 \Rightarrow 1) Suppose $q : A \rightarrow B$ is an R -epimorphism. Then we have an exact sequence

$$0 \rightarrow \ker q \hookrightarrow A \xrightarrow{q} B \rightarrow 0$$

which must be preserved by the exact functor ${}_{(\mathcal{A})}\text{Mod}(P, ?)$, so in particular ${}_{(\mathcal{A})}\text{Mod}(P, q)$ is an epimorphism. \square

Corollary 3.11. *Every direct summand of a projective \mathcal{A} -module is projective.*

Corollary 3.12. *\mathcal{A} is semisimple iff every finite-dimensional \mathcal{A} -module is projective.*

We denote the full subcategory of ${}_{(\mathcal{A})}\text{Mod}$ containing only projective modules by ${}_{(\mathcal{A})}\text{Proj}$.

RATHER THAN THINKING of simple \mathcal{A} -modules as having no proper nonzero submodules, we shift perspective slightly and view them as having no proper nonzero quotients. This makes the analogy to prime numbers more clear, for example we can find the “prime factors” of a module V by successively “dividing out” simple modules until we get to the zero module.

Definition 3.13. Let V be a finite-dimensional \mathcal{A} -module. A **Jordan-Hölder filtration** of V is a finite sequence of submodules $0 = V_0 < V_1 < \cdots < V_n = V$ such that V_i/V_{i-1} is simple for each i .

Lemma 3.14. *Every finite-dimensional \mathcal{A} -module admits a Jordan-Hölder filtration.*

Proof. The proof is by induction on $\dim(V)$, the base case is vacuously true. Pick a simple submodule $V_1 \leq V$, and let $U = V/V_1$ with canonical projection $\pi : V \rightarrow U$. By the induction assumption,

U has a Jordan-Hölder filtration $0 = U_0 < U_1 < \dots < U_{n-1} = U$. For $i \geq 2$ let $U_{i-1} = \pi^{-1}(U_i)$. Then $0 = V_0 < V_1 < \dots < V_n = V$ is a Jordan-Hölder filtration.¹⁴ □

We call the sequence of (isomorphism classes of) simple \mathcal{A} -modules appearing as quotients a **Jordan-Hölder series** of V , the corresponding multiset a **Jordan-Hölder decomposition**, and the simple modules appearing therein **composition factors** of V .

For most \mathcal{A} -modules we will have a degree of freedom as to which submodules appear in a Jordan-Hölder filtration, as shown in fig. 3.3. For this notion of decomposition to behave well, we want an analogue to the *fundamental theorem of arithmetic*.

Theorem 3.15 (Jordan-Hölder theorem). *Let V be a finite-dimensional \mathcal{A} -module. The Jordan-Hölder decomposition for V is unique.*

Proof. The proof is by induction on $\dim V$, the base case is clear. Let $0 = V_0 < V_1 < \dots < V_m = V$ and $0 = V'_0 < V'_1 < \dots < V'_n = V$ be Jordan-Hölder filtrations of V , and let $W_i := V_i/V_{i-1}$ and $W'_i = V'_i/V'_{i-1}$ denote the corresponding series. If $V_1 = V'_1$ we are done since the induction assumption implies V/V_1 has a unique Jordan-Hölder decomposition. Consider the case $V_1 \neq V'_1$, whence $V_1 \cap V'_1 = \emptyset$ by simplicity, so there is an embedding $f : V_1 \oplus V'_1 \hookrightarrow V$. Let $U = \text{coker } f$, and let $0 = U_0 < U_1 < \dots < U_p = U$ be a Jordan-Hölder filtration thereof. Then V/V_1 has Jordan-Hölder decompositions $[W'_1, Z_1, \dots, Z_p]$ and $[W_2, \dots, W_n]$ which coincide by the induction assumption. Similarly V/V'_1 has Jordan-Hölder decompositions $[W_1, Z_1, \dots, Z_p]$ and $[W'_2, \dots, W'_n]$ which coincide by the induction assumption. Thus we have the equality of multisets

$$[W_1, \dots, W_n] = [W_1, W'_1, Z_1, \dots, Z_p] = [W'_1, \dots, W'_n]$$

as required.¹⁵ □

Corollary 3.16. *Every isomorphism class has a representative in the Jordan-Hölder decomposition of \mathcal{A} . In particular, there are finitely many isomorphism classes $[S_1], \dots, [S_t]$ of simple \mathcal{A} -modules.*

Proof. Let S be a simple \mathcal{A} -module. Since S is nonzero, there exists a nonzero element $x \in S$, which by simplicity generates S , i.e. the \mathcal{A} -morphism $\pi : \mathcal{A} \rightarrow S : a \mapsto ax$ is an epimorphism, whence S is a quotient of \mathcal{A} . □

Definition 3.17. The **length** of an \mathcal{A} -module V is the length of its Jordan-Hölder series.

The other way of decomposing an \mathcal{A} -module V is perhaps more straightforward: Repeatedly break V into direct summands until all summands are indecomposable. A multiset of indecomposables obtained this way is called a **Remak decomposition** for V .

Lemma 3.18 (Fitting). *Let V be a finite-dimensional vector space and $\vartheta \in \text{End}_{\mathbb{K}}(V)$. Then $V = \ker \vartheta^n \oplus \text{im } \vartheta^n$ for all $n \gg 0$.*

¹⁴ Etingof et al., *Introduction to Representation Theory*, §3.4, p. 49.

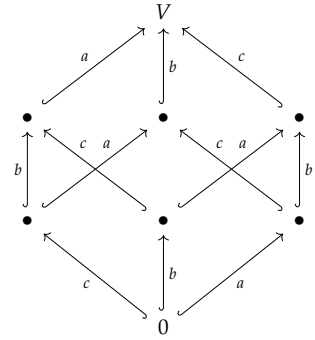

Figure 3.3: Jordan-Hölder decomposition of a CDih_6 -module with simple factors a, b, c . Each arrow is a monomorphism labelled by its cokernel. Adapted from Tubbenhauer, “What Is... the Jordan-Hölder Theorem?”

¹⁵ Etingof et al., §3.7, pp. 53–54.

Proof. The chain $\ker \vartheta^0 \leq \ker \vartheta^1 \leq \dots$ must eventually stabilize, say at $\ker \vartheta^m$. Let $n \geq m$. If $x \in \ker \vartheta^n \cap \text{im } \vartheta^n$, then $x = \vartheta^n(y)$ for some $y \in V$, whence $y \in \ker \vartheta^{2n} = \ker \vartheta^n$, so $x = 0$. Thus $\ker \vartheta^n \cap \text{im } \vartheta^n = 0$. By the rank-nullity theorem $\dim \ker \vartheta^n + \dim \text{im } \vartheta^n = \dim V$, so the statement follows.¹⁶ \square

Corollary 3.19. *Let V be an indecomposable finite-dimensional \mathcal{A} -module and $\vartheta \in \text{End}_{\mathcal{A}}(V)$. Then ϑ is either an automorphism or nilpotent.*

Proof. By lemma 3.18 there exists an $n \in \mathbb{N}$ such that $V = \ker \vartheta^n \oplus \text{im } \vartheta^n$, and since V is indecomposable one of these summands must be zero. If it is the former, ϑ is invertible, if it is the latter, ϑ is nilpotent. \square

Lemma 3.20. *Let V be a finite-dimensional vector space and $\vartheta \in \text{End}_{\mathbb{K}}(V)$ be nilpotent. Then $1 + \vartheta$ is an automorphism.*

Proof. Suppose $\vartheta^n = 0$. Then

$$(1 + \vartheta) \sum_{i=0}^{n-1} (-\vartheta)^i = 1$$

as required. \square

Lemma 3.21. *Let V be an indecomposable finite-dimensional \mathcal{A} -module and $\vartheta_1, \vartheta_2 \in \text{End}_{\mathcal{A}}(V)$ be nilpotent. Then $\vartheta := \vartheta_1 + \vartheta_2$ is nilpotent.*

Proof. Suppose towards contradiction ψ is an automorphism. Then there exists $\vartheta^{-1} \in \text{End}_{\mathcal{A}}(V)$ such that $\vartheta^{-1}\vartheta = \vartheta^{-1}\vartheta_1 + \vartheta^{-1}\vartheta_2 = 1_V$. Now the $\vartheta^{-1}\vartheta_i$ cannot be automorphisms,¹⁷ so by corollary 3.19 they must be nilpotent. On the other hand $1 - \vartheta^{-1}\vartheta_2$ is an automorphism by lemma 3.20. But $1 - \vartheta^{-1}\vartheta_2 = \vartheta^{-1}\vartheta_1$, a contradiction. \square

Theorem 3.22 (Krull-Schmidt theorem). *Let V be a finite-dimensional \mathcal{A} -module. The Remak decomposition for V is unique.*

Proof. Suppose $V = V_1 \oplus \dots \oplus V_m = V'_1 \oplus \dots \oplus V'_n$, and let $\pi_i : V \rightarrow V_i$, $\pi'_i : V \rightarrow V'_i$ denote the associated projections and $\iota_i : V_i \hookrightarrow V$, $\iota'_i : V'_i \hookrightarrow V$ the associated inclusions. Define $\vartheta_i = \pi_1 \iota'_1 \pi'_1 \iota_1 : V_1 \rightarrow V_1$, whence $\sum_{i=1}^n \vartheta_i = 1_{V_1}$. By lemmata 3.20 and 3.21, one of the ϑ_i must be an automorphism, without loss say $i = 1$. Let $f : \pi'_1 \iota_1 : V_1 \hookrightarrow V'_1$ and $g : \pi_1 \iota'_1 : V'_1 \rightarrow V_1$. Since $V'_1 = \text{im } f \oplus \ker g$, and $\text{im } f \neq 0$, it follows from indecomposability that $\text{im } f = V$ and $\ker g = 0$, whence f and g are isomorphisms. Applying this inductively on the remaining direct summands we can continue to find isomorphic pairs, showing the two Remak decompositions are the same. \square

It follows from corollary 3.11 that every projective module V is the direct sum of *projective* indecomposable modules, so projective indecomposable modules are well-behaved as atoms for ${}_{(\mathcal{A})}\text{Proj}$. As remarked previously, in general indecomposability is a weaker condition than simplicity, so in a sense there are too many indecomposable \mathcal{A} -modules for their classification to be practical; instead we restrict our attention to projective indecomposable \mathcal{A} -modules

¹⁶ Leinster, "The Bijection between Projective Indecomposable and Simple Modules," lemma 3.1, pp. 3-4.

¹⁷ Any preinverse would give a preinverse to ϑ_i , which is impossible since the latter is nilpotent.

as well as simple \mathcal{A} -modules. This approach is further justified by the following fundamental result:

Theorem 3.23. *There is a bijection between the isomorphism classes $[S_1], \dots, [S_t]$ of finite-dimensional simple \mathcal{A} -modules and $[P_1], \dots, [P_t]$ of projective modules determined by*

$$\dim {}_{(\mathcal{A})}\text{Mod}(P_i, S_j) = \delta_{ij}.$$

Moreover the multiplicity of P_i in the Remak decomposition of \mathcal{A} is $\dim S_i$ and the multiplicity of S_i in the Jordan-Hölder decomposition of \mathcal{A} is $\dim P_i$.

The module P_i is called the **projective cover** of V_i . Proving theorem 3.23 would take us too far, see the self-contained note by Leinster.¹⁸

IT IS CONVENIENT to describe the decomposition information just discussed in terms of certain abelian groups, known as *Grothendieck groups*.¹⁹

- $G_0\mathcal{A}$, the Grothendieck group of ${}_{(\mathcal{A})}\text{Mod}$, is the free abelian group generated by isomorphism classes of finite-dimensional \mathcal{A} -modules subject to the relation $U - V + W = 0$ for every exact sequence $0 \rightarrow U \hookrightarrow V \twoheadrightarrow W \rightarrow 0$.²⁰ By theorem 3.15 there is a \mathbb{Z} -basis consisting of the simple modules $[S_i]$ so that

$$[\mathcal{A}] = \sum_{j=1}^t (\dim P_j) [S_j] \in G_0\mathcal{A}.$$

Given a module $V \in {}_{(\mathcal{A})}\text{Mod}$, we denote the coefficient of $[S_i]$ in the basis expansion of $[V]$ by $[V : S_i]$.

- $K_0\mathcal{A}$, the Grothendieck group of ${}_{(\mathcal{A})}\text{Proj}$, is the free abelian group generated by isomorphism classes of finite-dimensional projective \mathcal{A} -modules subject to the relation $U - V + W = 0$ for every exact sequence $0 \rightarrow U \hookrightarrow V \twoheadrightarrow W \rightarrow 0$, i.e. whenever $V \cong_{\mathcal{A}} U \oplus W$.²¹ By theorem 3.22, there is a \mathbb{Z} -basis consisting of the indecomposable projective modules $[P_i]$ so that

$$[\mathcal{A}] = \sum_{i=1}^t (\dim S_i) [P_i] \in K_0\mathcal{A}.$$

Given a projective module $P \in {}_{(\mathcal{A})}\text{Proj}$, we denote the coefficient of $[P_i]$ in the basis expansion of $[P]$ by $[P : P_i]$.

It is straightforward to show that different equivalence classes of modules with the same Jordan-Hölder decompositions correspond give elements of $G_0\mathcal{A}$, while different isomorphism classes of projective modules give different elements of $K_0\mathcal{A}$.²² The coefficients $[V : S_i]$ and $[P : P_i]$ correspond to multiplicities in Jordan-Hölder and Remak decompositions respectively.

¹⁸ Leinster, “The Bijection between Projective Indecomposable and Simple Modules.”

¹⁹ The discussion here is based on Lorenz, “Representations of Finite-Dimensional Hopf Algebras,” §§1.1–1.2, pp. 478–79

²⁰ For the definition of exact sequences see §A.

²¹ By projectivity, every short exact sequence of projective modules splits.

²² From a projective modules image in $K_0\mathcal{A}$ we can reconstruct an isomorphic projective module via the direct sum of indecomposables.

Of course, ${}_{(\mathcal{A})}\text{Proj}$ is a full subcategory of ${}_{(\mathcal{A})}\text{Mod}$, and this inclusion induces the **Cartan map**

$$c : K_0\mathcal{A} \rightarrow G_0 : [P] \mapsto [P]$$

which sends the isomorphism class of a projective \mathcal{A} -module P to the equivalence class of modules with the same Jordan-Hölder series up to reordering. The corresponding matrix in terms of our designated bases is the **Cartan matrix**

$$\mathbf{C} = (C_{ij}) \in M_t(\mathbb{Z}) \quad C_{ij} = [P_i : S_j]$$

which gives the Jordan-Hölder decomposition of the indecomposable projective \mathcal{A} -modules in terms of simple \mathcal{A} -modules. Thus

$$c([P_i]) = \sum_{j=1}^t C_{ij}[S_j].$$

Proposition 3.24. *The Cartan map $c : K_0\mathcal{A} \rightarrow G_0\mathcal{A}$ is a group homomorphism.*

Proof. This follows from the fact that every exact sequence of projective \mathcal{A} -modules is a exact sequence of general \mathcal{A} -modules. \square

Given finite-dimensional \mathcal{A} -modules V , P , and Q where P and Q are projective, we define

$$\langle P, V \rangle = \dim {}_{(\mathcal{A})}\text{Mod}(P, V). \quad (3.1)$$

Proposition 3.25. *Let V be a finite-dimensional \mathcal{A} -module. Then $\langle P_i, V \rangle = [V : S_i]$.*

Proof. We prove by induction on the length of V . For a length 0 module the statement of proposition 3.25 is trivial. We will also need the case where $V = S_j$ is simple, where $\langle P_i, S_j \rangle = \delta_{ij} = [S_j : S_i]$.

Suppose now that proposition 3.25 holds for V of length $k - 1$. Let W be a module of length k . Then we have an exact sequence

$$0 \rightarrow S_j \hookrightarrow W \twoheadrightarrow V \rightarrow 0$$

for some simple module S_j and some V of length $k - 1$. By projectivity of P_j , the sequence

$$0 \rightarrow {}_{(\mathcal{A})}\text{Mod}(P_i, S_j) \hookrightarrow {}_{(\mathcal{A})}\text{Mod}(P_i, W) \twoheadrightarrow {}_{(\mathcal{A})}\text{Mod}(P_i, V) \rightarrow 0$$

is exact, whence

$$\begin{aligned} 0 &= \langle P_i, S_j \rangle - \langle P_i, W \rangle + \langle P_i, V \rangle \\ &= [S_j : S_i] - \langle P_i, W \rangle + [V : S_i] \\ &= [W : S_i] - \langle P_i, W \rangle, \end{aligned}$$

which is to say proposition 3.25 holds for V of length k . \square

Proposition 3.26. *Equation (3.1) induces a well-defined \mathbb{Z} -bilinear pairing*

$$\langle ?, ? \rangle : K_0\mathcal{A} \times G_0\mathcal{A} \rightarrow \mathbb{Z} \quad \langle [P], [V] \rangle = \langle P, V \rangle.$$

Proof. To see that this is independent of choice of representatives P and V and \mathbb{Z} -bilinear, expand $[P]$ and $[V]$ in terms of the designated bases. For the first argument apply proposition A.2, for the second apply proposition 3.25. \square

Corollary 3.27. *Let P be a finite-dimensional projective \mathcal{A} -module. Then $\langle P, S_i \rangle = [P : S_i]$.*

Proof. We have $\langle P_i, S_j \rangle = \delta_{ij} = [P_i, P_j]$, whence follow all other cases by \mathbb{Z} -bilinearity. \square

Proposition 3.28. *$\dim : G_0\mathcal{H} \rightarrow \mathbb{Z}$ and $\dim : K_0\mathcal{H} \rightarrow \mathbb{Z}$ define group homomorphisms.*

Proof. For any exact sequence $0 \rightarrow U \hookrightarrow V \rightarrow W \rightarrow 0$ we have the corresponding exact sequence in $\text{Vect}_{(\mathbb{K})}$, whence $\dim U - \dim V + \dim W = 0$. \square

3.3 Tannaka duality

In §2 we introduced a number of additional structures on a \mathbb{K} -monoid \mathcal{A} in search of category theoretic generalizations of algebraic structures such as groups. Here we motivate the introduction of these concepts from a second, representation theoretic angle. Tannaka duality, which can be seen as a vast generalization of Pontryagin duality,²³ studies the interplay between algebraic objects and their categories of representations, taking up the point of view that these are dual to each other. Given a category of representations, can we retrieve the underlying represented object? Exactly what kind of categories emerge as the categories of representations of what objects? The *Tannaka reconstruction theorems* answer these questions, giving bijections between equivalence classes of certain categories with extra structure, and isomorphism classes of certain algebraic objects. Full statement of the reconstruction theorems would take us too far, a comprehensive treatment for \mathbb{K} -bimonoids and Hopf \mathbb{K} -algebras is found in Etingof et al.²⁴ Our aim for this section is to provide an informal account of the Tannaka duals of bimonoids and various flavours of Hopf algebra.

²³ Joyal and Street, "An Introduction to Tannaka Duality and Quantum Groups," §1, p. 415.

²⁴ Etingof et al., *Tensor Categories*.

LET X BE A MONOID in a symmetric monoidal category \mathcal{C} and suppose we have a uniform way of giving X -module structure to the tensor product $R \otimes B$ for X -modules $R, B \in \mathcal{C}$. By uniform, we mean that the action should be of the form

$$(3.2)$$

where $\delta : X \rightarrow X \otimes X$ is independent of the modules R and B . For

this action to define a valid module, we need

(3.3)

and

(3.4)

Now if this tensor product of X -modules is to make ${}^{\mathbb{C}}_X \text{Mod}$ monoidal, we need an action θ on $\mathbb{1}$ satisfying²⁵

(3.5)

and

(3.6)

The compatibility conditions of eqs. (3.3) to (3.6) ensure that the data of δ and θ are precisely that of a comultiplication and counit for a bimonoid structure on X .²⁶ The module induced by the counit is called the **trivial module**.

Now let X be a bimonoid in a left rigid category \mathbb{C} and suppose we have a uniform way of giving X -module structure to the left dual R^* of any X -module R . Here uniform means the action is of the form

where $\zeta : X \rightarrow X$ is independent of the module R . Now if this notion of dual module is to make ${}^{\mathbb{C}}_X \text{Mod}$ a left rigid category, we need evaluation and coevaluation to be X -module homomorphisms. The former gives,

(3.7)

²⁵ We have drawn some instances of $\mathbb{1}$ as dotted lines for clarity. Recall that $\mathbb{1}$ strings are typically not drawn at all.

²⁶ It is clear from fig. 2.5 that such a comultiplication and counit satisfy eqs. (3.3) to (3.6). For the converse, consider the case $R = B = X$, the regular \mathcal{A} -module, and apply the actions to the unit.

the latter gives

$$(3.8)$$

whence $\zeta = \sigma$ is an antipous for X , so X is a Hopf monoid.²⁷ It follows that if σ is invertible and C is autonomous, then σ^{-1} induces the appropriate action on right duals. Moreover, if σ is involutive and C is pivotal, then the constructions for left dual and right dual modules coincide.

To summarize, given a monoid X in a category C

- monoidal structure on ${}^C_X\text{Mod}$ compatible with that of C is the same as bimonoidal structure on X ;
- left rigid structure on ${}^C_X\text{Mod}$ compatible with that of C is the same as Hopf monoid structure on X ;
- autonomous structure on ${}^C_X\text{Mod}$ compatible with that of C is the same as autonomous Hopf monoid structure on X ;
- pivotal structure on ${}^C_X\text{Mod}$ compatible with that of C is the same as involutive Hopf monoid structure on X .

Specializing back to $\text{Vect}_{(\mathbb{K})}$ and the involutive Hopf \mathbb{K} -algebra $\mathbb{K}G$ yields proposition 3.9 and the related structures on the category of group representations.

3.4 Representations of Hopf algebras

Given a group representation V , we call a vector $v \in V$ an **invariant** iff $gv = v$ for all $g \in G$, i.e. v transforms under the trivial representation. Generalizing to \mathcal{H} -modules, we call $v \in V$ an invariant iff $xv = \epsilon(x)v$ for all $x \in \mathcal{H}$, and the \mathcal{H} -submodule consisting of all invariants is denoted

$$V^{\mathcal{H}} = \{v \in V : xv = (\forall x \in \mathcal{H})[\epsilon(x)v]\}.$$

From §3.3 and proposition 2.32 we know that ${}_{\mathcal{H}}\text{Mod}$ is a closed monoidal category, but now is a good time to point out that the internal hom isn't quite the same as what we are used to in $\text{Vect}_{(\mathbb{K})}$.²⁸ Given finite-dimensional \mathcal{H} -modules R and B , the \mathcal{H} -module $R \multimap B = B \otimes R^*$ doesn't correspond to the set ${}_{(\mathcal{H})}\text{Mod}(R, B)$ but rather $\text{Vect}_{(\mathbb{K})}(R, B)$. Thus if $f : R \rightarrow B$ is a \mathbb{K} -linear map, then xf is

²⁷ It is clear from eq. (2.4) that the antipous satisfies eqs. (3.7) and (3.8). For the converse, take $R = X$ to be the regular X -module, apply the zigzag identities, and apply the action to the unit.

²⁸ This shouldn't be surprising, after all this internal hom was constructed to be a right adjoint to the \mathbb{K} -tensor product $(\otimes_{\mathbb{K}})$, which itself is constructed to be a left adjoint to the internal hom of $\text{Vect}_{(\mathbb{K})}$. If we wanted an internal hom which only gave \mathcal{H} -module morphisms, we would need some notion of \mathcal{H} -tensor product $(\otimes_{\mathcal{H}})$. Such a notion exists, but it won't be an \mathcal{H} -module unless \mathcal{H} is commutative. See Aluffi, *Algebra*, §VIII.2, p. 500.

the \mathbb{K} -linear map

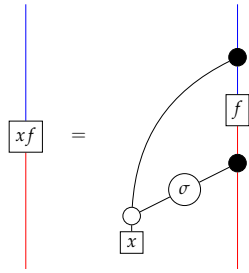

for $x \in \mathcal{H}$. We can however easily obtain a submodule of \mathcal{H} -morphisms.

Proposition 3.29. For any finite-dimensional \mathcal{H} -modules R and B , the space of H -invariants $(R \dashv B)^{\mathcal{H}}$ is precisely the space of H -module maps.

Proof. If $f : R \rightarrow B$ is an \mathcal{H} -module map, then

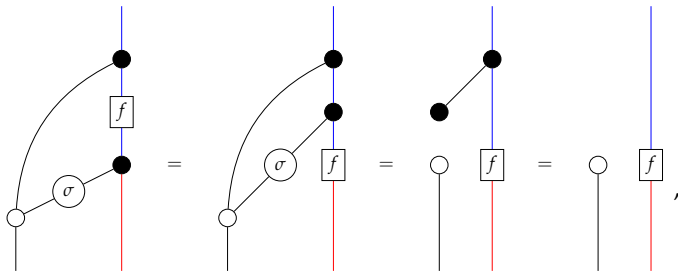

so $f \in (R \dashv B)^{\mathcal{H}}$. Similarly, if $f \in (R \dashv B)^{\mathcal{H}}$, then

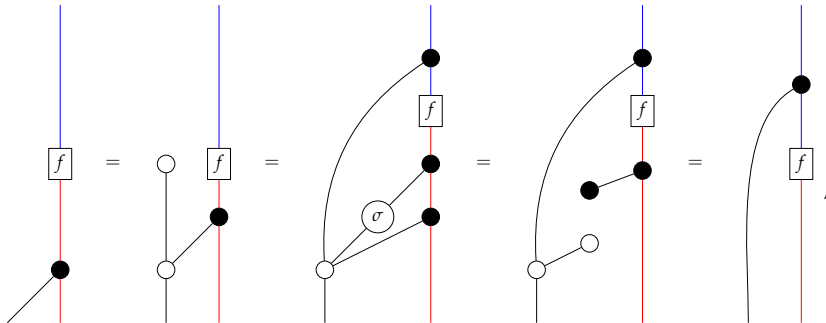

so f is an \mathcal{H} -module map. □

Proposition 3.30. Let V, P be a finite-dimensional \mathcal{H} -modules with P projective. Then $P \otimes V$ is projective.

Proof. By the chain of adjunctions $? \otimes V \dashv ? \otimes V^* \dashv V^{**}$, the functor $? \otimes V^*$ is both a left and right adjoint whence it is exact by proposition A.7. As the composition of exact functors, ${}_{(\mathcal{A})}\text{Mod}(P \otimes V, ?) \simeq {}_{(\mathcal{A})}\text{Mod}(P, ? \otimes V^*)$ is exact, whence $P \otimes V$ is projective. □

For a Hopf \mathbb{K} -algebra \mathcal{H} , the monoidal structure of ${}_{(\mathcal{H})}\text{Mod}$ induces associative multiplications on the Grothendieck groups $G_0\mathcal{H}$ and $K_0\mathcal{H}$ via

$$[V][W] = [V \otimes W]$$

so that the former becomes a ring and the latter a rng.²⁹ Expanding

²⁹ $K_0\mathcal{H}$ will only be a ring if the trivial module \mathcal{H} is projective. But from corollary 3.12 and proposition 3.30 it follows this is the case iff \mathcal{H} is semisimple.

on proposition 3.28, $\dim : K_0\mathcal{H} \rightarrow \mathbb{Z}$ becomes a ring morphism.³⁰ By proposition 3.30, $K_0\mathcal{H}$ is a right $G_0\mathcal{H}$ -module, whence by proposition 3.24 the Cartan map is both a ring morphism and right $G_0\mathcal{H}$ -module morphism. We can also induce a ring antiautomorphism via left duals:

Proposition 3.31. *Let V, W be finite-dimensional \mathcal{H} -modules. Then $[V] = [W]$ iff $[V^*] = [W^*]$ in $K_0\mathcal{H}$.*

Proof. There exists an exact sequence $0 \rightarrow U \rightarrow V \rightarrow W \rightarrow 0$ iff there exists an exact sequence $0 \rightarrow W^* \rightarrow V^* \rightarrow U^* \rightarrow 0$, so $[V] = [U] + [W]$ iff $[V^*] = [U^*] + [W^*]$. \square

From now on we will abuse notation and write V instead of $[V]$ for the equivalence class of an \mathcal{H} -module in $G_0\mathcal{H}$ or $K_0\mathcal{H}$.

Proposition 3.32. *For $V, W \in G_0\mathcal{H}$ and $P \in K_0\mathcal{H}$ we have*

$$\langle PV, W \rangle = \langle P, WV^* \rangle.$$

Proof. This follows directly from corollary 2.33. \square

3.5 Bimonoid and Hopf faithful representations

The previous sections have shown that the representation theory of finite-dimensional Hopf \mathbb{K} -algebras is a generalization of that of finite groups retaining many nice features, and in particular that little is lost from viewing representations of a group G as representations of the corresponding group algebra $\mathbb{K}G$. A slightly uncomfortable situation remains in the question of faithfulness. A notion of faithfulness exists for modules over a \mathbb{K} -algebra \mathcal{A} , namely an \mathcal{A} -module V is called faithful iff the corresponding \mathbb{K} -algebra homomorphism $\rho_V : \mathcal{A} \rightarrow \text{End}_{\mathbb{K}}(V)$ is injective, i.e. $\ker \rho_V = 0$. We will call this property **monoid faithfulness** of the \mathcal{A} -module V . Monoid faithfulness of a $\mathbb{K}G$ -module does not agree with faithfulness of the corresponding group representation — the former is far more restrictive.³¹

And why should they coincide? Monoid faithfulness completely ignores any of the Hopf algebra structure we have spent all this time emphasizing the importance of. A solution to this thorny issue was proposed by Banica and Bichon.³²

Definition 3.33. A finite-dimensional \mathcal{H} -module V is **Hopf faithful** iff $\ker \rho_V$ does not contain a nonzero Hopf ideal.

Banica and Bichon motivate this definition partly by the fact that it aligns with the classical notions of faithful representations of groups and Lie algebras, the first of which we show in proposition 3.35. We propose a stronger condition defined for any \mathbb{K} -bimonoid \mathcal{B} , which aligns with these classical examples just as well.

Definition 3.34. A finite-dimensional \mathcal{B} -module V is **bimonoid faithful** iff $\ker \rho_V$ does not contain a nonzero biideal.

³⁰ A \mathcal{K} -algebra homomorphism of a \mathcal{K} -algebra into \mathcal{K} is known as an **augmentation**. Besides \dim , the counit of a \mathcal{K} -bimonoid is another example of an augmentation.

³¹ Take $G = \langle a : a^2 = 1 \rangle$. For $\text{char } \mathbb{K} \neq 2$, take the $\mathbb{K}G$ -module $V = \mathbb{K}$ such that $a1 = -1$. Then V is faithful as a group representation, but since $a + 1 \in \ker \rho_V$ it is not outer faithful. On the other hand, if V is a representation of any group G which is not faithful as a group representation, i.e. there exists $1 \neq g \in G$ such that $gv = v$, then $g - 1 \in \ker \rho_V$, so V is not outer faithful.

³² Banica and Bichon, “Hopf Images and Inner Faithful Representations.” Our terminology differs slightly from that originally used by the authors.

Proposition 3.35 (*). *Let G be a group and V be a $\mathbb{K}G$ -module. Then V is Hopf faithful iff it is monoid faithful iff the group morphism $\rho_V \upharpoonright G : G \rightarrow \text{GL}(V)$ is injective.*

Proof. It is clear that bimonoid faithfulness implies Hopf faithfulness, so to start we show that classical faithfulness implies bimonoid faithfulness. Suppose ρ_V is not bimonoid faithful, so there exists a nonzero biideal $I \subseteq \ker \rho_V$. Let $\mathbb{K}G/I$ be the quotient \mathbb{K} -bimonoid and $\pi : \mathbb{K}G \rightarrow \mathbb{K}G/I$ the canonical projection. We have a factorization φ shown in fig. 3.4. Taking grouplikes gives a monoid morphism $\text{Gr}(\pi) : G \rightarrow \text{Gr}(\mathbb{K}G/I)$, where $\text{im Gr}(\pi)$ must be a proper quotient of G so that $1 < \ker \text{Gr}(\pi) \leq \ker(\rho_V \upharpoonright G)$, wherefore $\rho_V \upharpoonright G$ is not injective. Therefore classical faithfulness implies bimonoid faithfulness.

Finally we show that Hopf faithfulness implies classical faithfulness. Suppose $\rho_V \upharpoonright G$ is not injective, so $1 \neq N = \ker \rho_V$. We then have a factorization φ shown in fig. 3.5. Taking group algebras and extending group homomorphisms linearly gives the commutative diagram in fig. 3.6, whence $\ker \mathbb{K}\pi \leq \ker \rho_V$ where the former is a nonzero Hopf ideal, so ρ_V is not Hopf faithful. Therefore Hopf faithfulness implies classical faithfulness. \square

It is useful to define the notions of **Hopf kernel** and **bimonoid kernel** for the maximal Hopf ideal and biideal respectively contained within $\ker \rho_V$. The following construction of the bimonoid kernel is adapted from the construction of the Hopf kernel given by Banica and Bichon.³³

Proposition 3.36 (*). *Let V be a finite-dimensional \mathcal{B} -module. The bimonoid kernel of V is*

$$I_V = \bigcap_{i=0}^{\infty} \ker \rho_V^{(n)} \leq_{\mathbb{K}} \mathcal{B}$$

where $\rho_V^{(n)} := \rho_{V^{\otimes n}} = \rho_V^{\otimes n} \Delta_n : \mathcal{B} \rightarrow \text{End}_{\mathbb{K}}(V^{\otimes n})$ for $n \in \mathbb{N}_0$.

We prove proposition 3.36 by means of two lemmata. By construction I_V is an ideal, the following ensures it is a biideal.

Definition 3.37. Let V be a finite-dimensional \mathcal{B} -module. A **representative form** on \mathcal{B} induced by V is an element of the set³⁴

$$\text{rep}_V(\mathcal{B}) = \text{span}_{\mathbb{K}} \{ \psi \rho_V : \psi \in \text{End}_{\mathbb{K}}(V)^* \} \leq_{\mathbb{K}} \mathcal{B}^*.$$

Lemma 3.38 (*). *Let $C_V := \bigcup_{n=0}^{\infty} \text{rep}_{V^{\otimes n}}(\mathcal{B})$. Then C_V is a \mathbb{K} -submonoid of \mathcal{B}^* with $I_V = C_V^{\perp}$. In particular I_V is a coideal of \mathcal{B} .*

Proof. Let $(*)$ denote the product on \mathcal{B}^* . For $\psi, \phi \in \mathcal{B}^*$ and $m, n \in \mathbb{N}_0$ we have

$$\psi \rho_V^{(m)} * \phi \rho_V^{(n)} = (\psi \rho_V^{(m)} \otimes \phi \rho_V^{(n)}) \Delta = (\psi \otimes \phi) \rho_V^{(n+m)} \in C_V$$

and $\epsilon^* \in C_V$, so C_V is a \mathbb{K} -submonoid of \mathcal{B}^* . Moreover we see $I_V = C_V^{\perp}$, so I_V is a coideal by proposition 2.48. \square

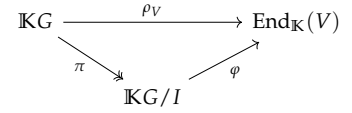

Figure 3.4: Factorization of a representation via a quotient bimonoid.

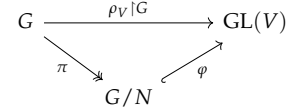

Figure 3.5: Factorization of a representation via a quotient group.

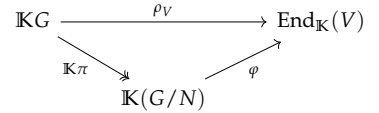

Figure 3.6: Constructing a nonzero Hopf ideal from a normal subgroup.

³³ Banica and Bichon, “Hopf Images and Inner Faithful Representations,” proposition 2.2, p. 680.

³⁴ After choosing a basis for V , the representation $\rho_V(x)$ becomes a matrix for each $x \in \mathcal{B}$. The map taking x to the (i, j) th entry of the matrix ρ_V is then a linear form, and thus an element of \mathcal{B}^* . The space $\text{rep}_V(\mathcal{B})$ is spanned by all such linear forms.

The following lemma completes the proof of proposition 3.36.³⁵

Lemma 3.39 (\star). *Let $\pi : \mathcal{B} \rightarrow \mathcal{Q}$ be a \mathbb{K} -bimonoid morphism factorizing ρ_V so that $\rho_V = \varphi\pi$ for some \mathbb{K} -monoid morphism $\varphi : \mathcal{Q} \rightarrow \text{End}_{\mathbb{K}}(V)$. Then $\ker \pi \subseteq I_V$.*

Proof. We show by induction on $n \in \mathbb{N}_0$ that $\rho_V^{(n)} = \varphi^{(n)}\pi$ with the same notation for φ as for ρ_V . The base case is clear since $\rho_V^{(0)} = \epsilon = \epsilon\pi = \varphi^{(0)}\pi$. For the induction step

$$\begin{aligned} \rho_V^{(n+1)} &= (\rho_V^{(n)} \otimes \rho_V)\Delta = (\varphi^{(n)}\pi \otimes \varphi\pi)\Delta \\ &= (\varphi^{(n)} \otimes \varphi)\Delta\pi = \varphi^{(n+1)}\pi \end{aligned}$$

as required. It follows $\ker \pi \subseteq \ker \rho_V^{(n)}$ for all $n \in \mathbb{N}_0$ whence $\ker \pi \subseteq I_V$. \square

³⁵ Specifically lemma 3.39 implies that any biideal J contained in $\ker \rho_V$ is contained in I_V , since for any such biideal we may factor ρ_V via the canonical projection $\pi : \mathcal{B} \rightarrow \mathcal{B}/J$ where $\ker \pi = J$. Since I_V is itself a biideal, this implies it is the maximal biideal contained in $\ker \rho_V$.

4

McKay quivers of finite-dimensional Hopf algebras

Given a group G and a \mathbb{C} -representation V , the **McKay quiver** for G at V is a quiver containing information about how tensor products with V decompose. If V_1, \dots, V_t are the irreducible \mathbb{C} -representations of G , let $M_{ij} \in \mathbb{N}_0$ so that

$$V_i \otimes V = \bigoplus_{j=1}^t V_j^{\oplus M_{ij}}.$$

The matrix $\mathbf{M}_V = (M_{ij})$ is called the **McKay matrix** of G at V and is the adjacency matrix for the McKay quiver, an example of which is given in fig. 4.1.

This construction was first proposed by McKay,¹ who observed that if G is a finite subgroup of $SU(2)$ and $V = \mathbb{C}^2$ with the natural action of G , the McKay quiver is one the affine Dynkin diagrams of type $\tilde{A}_n, \tilde{D}_n,$ or \tilde{E}_n . This empirical observation sets up a bijective correspondence between isomorphism classes of finite subgroups of $SU(2)$ and simply laced Dynkin diagrams, known as the **McKay correspondence**. Connections to other areas of mathematics abound, as the same Dynkin diagrams classify regular polyhedra, certain semisimple Lie algebras, and Kleinian singularities, among others.²

A fundamental result about McKay quivers, already observed by McKay in his original note on the subject, is that the McKay quiver of G at V is strongly connected whenever V is a faithful representation of G , a consequence of the fact that any representation appears in some tensor power of V when V is faithful.³ More recently, results on connectivity properties of McKay quivers were expanded upon by Browne, who showed that the strongly connected and weakly connected components of McKay quivers coincide, and characterized the connected components of McKay quivers at non-faithful representations.⁴

THE SET UP for McKay quivers makes sense anywhere we can meaningfully talk about tensor products of representations and their decompositions into “atoms,” and thus for Hopf \mathbb{K} -algebras,⁵ so that the above becomes the special case of the McKay quiver of $\mathbb{K}G$ at V . Using the toolkit of §§3.2 and 3.4, the above definition

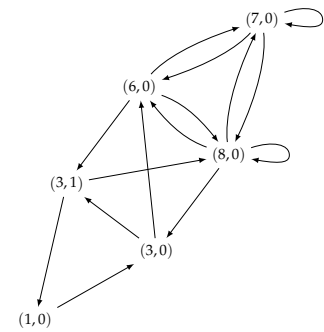

Figure 4.1: The McKay quiver of $PSL_3(2)$ at $V(3,0) = V(3,1)^*$. Here $V(d, i)$ is a d -dimensional simple module.

¹ McKay, “Graphs, Singularities, and Finite Groups.”

² Buchweitz, “From Platonic Solids to Preprojective Algebras via the McKay Correspondence.”

³ Buchweitz, p. 22.

⁴ Browne, “Connectivity Properties of McKay Quivers.”

⁵ Indeed, it was in considering the most general context in which McKay quivers make sense that lead the author to the subject of bimonoids and Hopf monoids in the first place.

may be reformulated for a finite-dimensional Hopf \mathbb{K} -algebra \mathcal{H} so that the McKay matrix of \mathcal{H} at V is

$$\mathbf{M}_V = (M_{ij}), \quad M_{ij} := [S_i \otimes V : S_j].$$

Research on McKay quivers in this generality is fairly recent. A series of papers by Chan et al. proved a quantum analogue of the classical McKay correspondence for Hopf algebras called *quantum binary polyhedral groups* at representations induced by their actions on certain noncommutative \mathbb{K} -monoids called *quantum planes*.⁶ McKay quivers of general Hopf algebras were considered by Grinberg, Huang, and Reiner in the context of the chip-firing game, where it was first observed that dimensions of simple modules give a right eigenvector to the McKay matrix.⁷ In a similar vein, a paper by Benkart et al. explored the statistical properties of certain Markov chains constructed from McKay quivers of Hopf algebras.⁸ A later paper by Benkart et al. expanded results on the eigenvectors of McKay matrices for finite-dimensional Hopf algebras, by showing how (generalized) eigenvectors can be constructed using the Grothendieck groups $G_0\mathcal{H}$ and $K_0\mathcal{H}$ and the traces of representations.⁹ The authors of this final paper remark in the introduction that theretofore very little was known about the eigenvalues and eigenvectors of the McKay matrices for arbitrary finite-dimensional Hopf algebras, especially in the non-semisimple case.

Still, very little work has been done to characterize the graph-theoretic properties of the McKay quivers of arbitrary finite-dimensional Hopf algebras, in particular about their connectivity properties. Whether strong and weak connectedness are equivalent, or what conditions on a \mathcal{H} -module V are sufficient to guarantee a connected McKay quiver of \mathcal{H} at V remain open questions.

In this chapter, all notations from §3 remain in effect, and V is some finite-dimensional \mathcal{H} -module.

4.1 Cartan duality

For the McKay quiver of a \mathbb{K} -bimonoid which is not semisimple, it is not a priori clear whether the correct approach is as above, in terms of simple \mathcal{A} -modules, or in terms of indecomposable projective \mathcal{A} -modules, as given by the adjacency matrix

$$\mathbf{Q}_V = (Q_{ij}), \quad Q_{ij} := [P_i \otimes V : P_j]$$

While this situation may initially seem uncomfortable, it was shown by Benkart et al. that for a Hopf \mathbb{K} -algebra

$$\mathbf{Q}_V = \mathbf{M}_{V^*}^T$$

which we review here.¹⁰

Proposition 4.1. *For any H -module V , $\mathbf{Q}_V \mathbf{C} = \mathbf{C} \mathbf{M}_V$.*

⁶ Chan et al., “Quantum Binary Polyhedral Groups and Their Actions on Quantum Planes”; Chan et al., “McKay Correspondence for Semisimple Hopf Actions on Regular Graded Algebras, I”; Chan et al., “McKay Correspondence for Semisimple Hopf Actions on Regular Graded Algebras. II.”

⁷ Grinberg, Huang, and Reiner, “Critical Groups for Hopf Algebra Modules.”

⁸ Benkart et al., “Tensor Product Markov Chains.”

⁹ Benkart et al., “McKay Matrices for Finite-Dimensional Hopf Algebras.”

¹⁰ Benkart et al.

Proof. In K_0H we have $[P_i \otimes V] = \sum_{j=1}^m Q_{ij}[P_j]$, which applying the Cartan map gives

$$[P_i \otimes V] = \sum_{j=1}^m Q_{ij} [P_j] = \sum_{j,k=1}^m Q_{ij} C_{jk} [S_k]$$

in G_0H . On the other hand, we have

$$[P_i \otimes V] = [P_i][V] = \sum_{j=1}^m C_{ij} [S_j][V] = \sum_{j,k} C_{ij} M_{jk} [S_k]$$

whence $Q_V C = C M_V$. \square

Theorem 4.2. *Let $V \in H$ be a module, V^* be its dual, and*

$$Q_V = (Q_{ij}), \quad M_{V^*} = (M_{ij}^*)$$

be their projective and simple McKay matrices respectively. Then

$$Q_{ij} = \langle P_i V, S_j \rangle = \langle P_i, S_j V^* \rangle = M_{ji}^*$$

and thus $Q_V = M_{V^}^T$.*

This is the analogue to the classical result that taking the dual of a $\mathbb{K}G$ -module corresponds to reversing the arrows of a McKay quiver, see e.g. Browne.¹¹

¹¹ Browne, "Connectivity Properties of McKay Quivers," proposition 2.5.

4.2 A conjecture

In moving from classical McKay quivers to the more general context of finite-dimensional Hopf algebras which may not be semisimple, some of the representation theoretic toolkit used to prove results is lost. For example, many properties of the representations and Grothendieck groups of finite groups are determined by *characters*, scalar functions on G given by the matrix traces of representations. While generalizations of character theory for certain classes of Hopf algebras exist,¹² these are limited in scope. Thus to generalize connectivity results it is first necessary to formulate the special case of finite groups in a character-free manner. For some propositions this is easily done, for example:

Proposition 4.3 (\star). *There exists a walk of length $L \geq 0$ from S_i to S_j in Γ_V iff $[S_i \otimes V^{\otimes L} : S_j] \geq 1$.*

Proof. We prove by induction on L . For $L = 0$ the statement is trivial. Suppose the statement holds for walks of length $L - 1$. A walk of length $L \geq 1$ from S_i to S_j is equivalent to a walk of length $L - 1$ from S_i to S_k where S_k is adjacent to S_j , i.e. $[S_k \otimes V : S_j] \geq 1$. By our induction hypothesis, this is equivalent to there existing an S_k such that $[S_i \otimes V^{\otimes(L-1)} : S_k] \geq 1$ and $[S_k \otimes V : S_j] \geq 1$, which in turn is equivalent to $[S_i \otimes V^{\otimes L} : S_j] \geq 1$. Thus the statement holds for walks of length L .¹³ \square

¹² see e.g. Larson, "Characters of Hopf Algebras"; Witherspoon, "The Representation Ring and the Centre of a Hopf Algebra"

¹³ cf. Browne, "Connectivity Properties of McKay Quivers," lemma 3.2, p. 187

The following conjecture is suggested by its validity in a number of special cases and a formal similarity to the ingredients in the character-dependent proof for representations of finite groups.

Conjecture 4.4 (*). *The McKay quiver of \mathcal{H} at V is strongly connected if V is bimonoid faithful.*

4.3 Nonclassical examples of McKay quivers

4.3.1 The algebra of functions on a group

Let G be a group and consider the Hopf algebra \mathbb{K}^G as in definition 2.55. In order to construct the McKay quiver of G , we must first construct its simple modules. Since \mathbb{K}^G is commutative, it follows all simple \mathbb{K}^G -modules are 1-dimensional.

Proposition 4.5. *Let \mathcal{H} be a finite-dimensional Hopf \mathbb{K} -algebra. The 1-dimensional \mathcal{H} -modules are given by grouplikes of \mathcal{H}^* .*

Proof. A linear form $f \in \mathcal{H}^*$ is grouplike precisely when $f(x)f(y) = (f \otimes f)(x \otimes y) = \mu^*(f)(x \otimes y) = f(xy)$ for all $x, y \in \mathcal{H}$, and by proposition 2.36 these also satisfy $1^*(f) = f(1) = 1$. Therefore $\text{Gr}(\mathcal{H}^*) = \text{Mon}_{\mathbb{K}}(\mathcal{H}, \mathbb{K}) \subset \mathcal{H}^*$ is the subset consisting of \mathbb{K} -monoid morphisms. On the other hand, the action of \mathcal{H} on a 1-dimensional module must be given precisely by such a \mathbb{K} -monoid morphism. □

Corollary 4.6. *Each simple \mathbb{K}^G -module is given by $\mathbb{K}x$ for an element $x \in G$, with the action $f \triangleright x = f(x)x$.*

For $x \in G$ let $\delta_x \in \mathbb{K}^G$ denote the function defined by $\delta_x(y) = 1$ if $y = x$ and $\delta_x(y) = 0$ otherwise. Then it follows from the isomorphism

$$\mathbb{K}^G = \bigoplus_{x \in G} \mathbb{K}\delta_x \cong_{\mathbb{K}^G} \bigoplus_{x \in G} \mathbb{K}x$$

that \mathbb{K}^G is semisimple. The comultiplication of \mathbb{K}^G gives the action

$$f \triangleright (x \otimes y) = f(xy) x \otimes y$$

on the tensor product, so we see $\mathbb{K}x \otimes \mathbb{K}y \cong_{\mathbb{K}^G} \mathbb{K}xy$. The antipous induces the duality $(\mathbb{K}x)^* = \mathbb{K}x^{-1}$. It follows that the Grothendieck group $G_0\mathbb{K}^G = K_0\mathbb{K}^G \cong_{\text{Mon}_{\mathbb{Z}}} \mathbb{Z}G$ is precisely the group \mathbb{Z} -algebra of G .

Theorem 4.7 (*). *A McKay quiver of \mathbb{K}^G is precisely a Cayley graph.*¹⁴

Proof. For a joining set J , let $V_J = \bigoplus_{x \in J} \mathbb{K}x$, and form the McKay quiver of \mathbb{K}^G at J . Then there exists an edge from $\mathbb{K}x$ to $\mathbb{K}y$ precisely when $\mathbb{K}y$ appears in the decomposition of $\mathbb{K}y \otimes V_J$, which happens iff $yz = x$ for some $z \in J$. An example is given in fig. 4.2. Of course, if there is a multiplicity in V_J we get a degenerate case which can be thought of as a Cayley graph with a joining multi-set. □

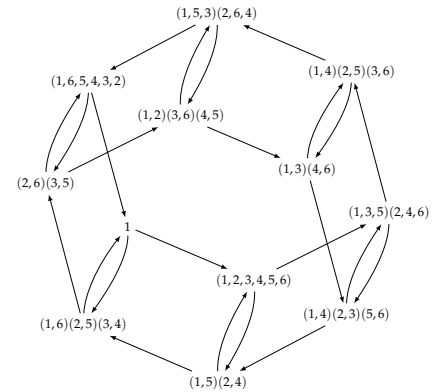

Figure 4.2: The Cayley graph of Dih_6 where $J = \{(123456), (16)(25)(34)\}$.

¹⁴ Recall that the **Cayley graph** of a group G with joining set J is the quiver whose vertices are elements of G , and there exists an edge from x to y iff there exists a $z \in J$ such that $xz = y$.

Corollary 4.8 (*). *The McKay quiver of \mathbb{K}^G at V_J is strongly connected iff V_J is bimonoid faithful.*

Proof. Thinking of the McKay quiver as a Cayley graph, we see that it is strongly connected iff J is a generating set for G , since a walk from $1 \in G$ to $x \in G$ corresponds to a sequence of elements in J multiplying to give x . On the other hand, we can construct the bimonoid kernel I_V of V_J using lemma 3.38 as the orthogonal complement of $C_V = \bigcup_{n=0}^{\infty} \text{rep}_{V_J^{\otimes n}}(\mathbb{K}^G)$. Now $\text{rep}_{V_J^{\otimes n}}(\mathbb{K}^G)$ is the sum of $\text{rep}_{\mathbb{K}x}(\mathbb{K}^G)$ for each simple constituent $\mathbb{K}x$ of V_J , and thus each x expressible as a product of n elements in J . Under the identification $(\mathbb{K}^G)^* \cong \mathbb{K}G$, we see that $\text{rep}_{\mathbb{K}x}(\mathbb{K}^G) = \mathbb{K}x \leq_{\mathbb{K}} \mathbb{K}G$, whence $C_V = \mathbb{K}\langle J \rangle$, where $\langle J \rangle$ is the subgroup generated by J . Therefore $C_V = \mathbb{K}G$, and thus $I_V = C_V^{\perp} = 0$, iff J generates G .¹⁵ \square

4.3.2 The Drinfel'd double of the Taft algebra

We follow the example of Benkart et al. in taking the Drinfel'd double \mathcal{D}_n of the Taft algebra \mathcal{H}_n as defined in definition 2.57 as a convenient testing ground for the non-classical case.¹⁶ The utility of \mathcal{D}_n lies in the fact it is a non-semisimple quantum group whose representation theory has been developed extensively by Chen et al.¹⁷ As with all quantum doubles there is a natural braiding on ${}_{\mathcal{D}_n}\text{Mod}$ so that $V \otimes W \cong W \otimes V$ for any \mathcal{D}_n -modules V, W .¹⁸

Theorem 4.9 (Chen). *The simple \mathcal{D}_n -modules $V(\ell, r)$ are indexed by a pair (ℓ, r) where $1 \leq \ell \leq n$ and $r \in \mathbb{Z}_n := \mathbb{Z}/n\mathbb{Z}$. Then $V(\ell, r)$ is a \mathbb{K} -vector space of dimension ℓ with standard basis $\{v_1, \dots, v_{\ell}\}$ and \mathcal{D}_n -action defined by*

$$\begin{aligned} av_i &= \begin{cases} v_{i+1} & 1 \leq i < \ell \\ 0 & i = \ell \end{cases}, & dv_i &= \begin{cases} 0 & i = 0 \\ \alpha_{i-1}(\ell)v_{i-1} & 1 < i \leq \ell' \end{cases} \\ bv_i &= q^{r+i-1}v_i, & cv_i &= q^{i-r-1}v_i \end{aligned}$$

for $1 \leq i \leq \ell$ where

$$\alpha_i(\ell) = \frac{(q^i - 1)(1 - q^{i-\ell})}{q - 1}$$

for $1 \leq i \leq n - 1$.¹⁹

In particular we see that $V(1, 0)$ is the trivial \mathcal{D}_n -module induced by the counit ϵ . Let $\kappa(\tau) := \lfloor \frac{\tau+1}{2} \rfloor$.

Theorem 4.10 (Chen). *The projective cover $P(\ell, r)$ of $V(\ell, r)$ is a $2n$ -dimensional \mathcal{D}_n -module with Jordan-Hölder decomposition so that the Cartan map is given by $[P(\ell, r)] = 2[V(\ell, r)] + 2[V(n - \ell, r + \ell)] = [P(n - \ell, \ell + r)]$ in $G_0\mathcal{D}_n$ for $\ell < n$ and $[P(n, r)] = [V(n, r)]$ otherwise. Moreover, the simple modules $V(\ell, r)$ and their projective covers $P(\ell, r)$ form the complete set of finite-dimensional indecomposable \mathcal{D}_n -modules.²⁰*

¹⁵ If we had instead constructed I_V directly via proposition 3.36, we would have found that $\ker \rho_V^{(n)}$ is the set of all $f \in \mathbb{K}^G$ such that $f(x) = 0$ for any x expressible as a product of n elements in J .

¹⁶ Benkart et al., "McKay Matrices for Finite-Dimensional Hopf Algebras."

¹⁷ Chen, "A Class of Noncommutative and Noncocommutative Hopf Algebras"; Chen, "Irreducible Representations of a Class of Quantum Doubles"; Chen, "Finite-Dimensional Representations of a Quantum Double"; Chen, "Representations of a Class of Drinfeld's Doubles"; Chen, Mohammed, and Sun, "Indecomposable Decomposition of Tensor Products of Modules over Drinfeld Doubles of Taft Algebras."

¹⁸ Kashaev, "The Quantum Double," p. 93.

¹⁹ Chen, "Irreducible Representations of a Class of Quantum Doubles," §2.

²⁰ Chen, "Representations of a Class of Drinfeld's Doubles," §2.

Theorem 4.11 (Chen, Mohammed, and Sun). *The tensor product of simple \mathcal{D}_n -modules is given by the Remak decomposition*

$$V(\ell, r) \otimes V(\ell', r') \cong \bigoplus_{i=0}^{\ell-1} V(\ell + \ell' - 1 - 2i, r + r' + i)$$

for $1 \leq \ell \leq \ell' \leq n$ and $\ell + \ell' \leq n + 1$, and

$$V(\ell, r) \otimes V(\ell', r') \cong \bigoplus_{i=\kappa(\tau)}^{\tau} P(\ell + \ell' - 1 - 2i, r + r' + i) \oplus \bigoplus_{i=\tau+1}^{\ell-1} V(\ell + \ell' - 2i, r + r' + i)$$

for $\tau := \ell + \ell' - (n + 1) \geq 0$.²¹

Theorems 4.10 and 4.11 allow us to find the product of any two modules $[V], [W] \in G_0\mathcal{D}_n$, by first finding the Remak decomposition and then applying the Cartan map to the projective part thereof. A SageMath implementation of the ring $K_0\mathcal{D}_n$ using these results is given in §B, as well as code for rendering the corresponding McKay quivers. Figures 4.3 and 4.4 show examples of the McKay quivers generated this way.

²¹ Chen, Mohammed, and Sun, “Indecomposable Decomposition of Tensor Products of Modules over Drinfeld Doubles of Taft Algebras,” proposition 3.1.

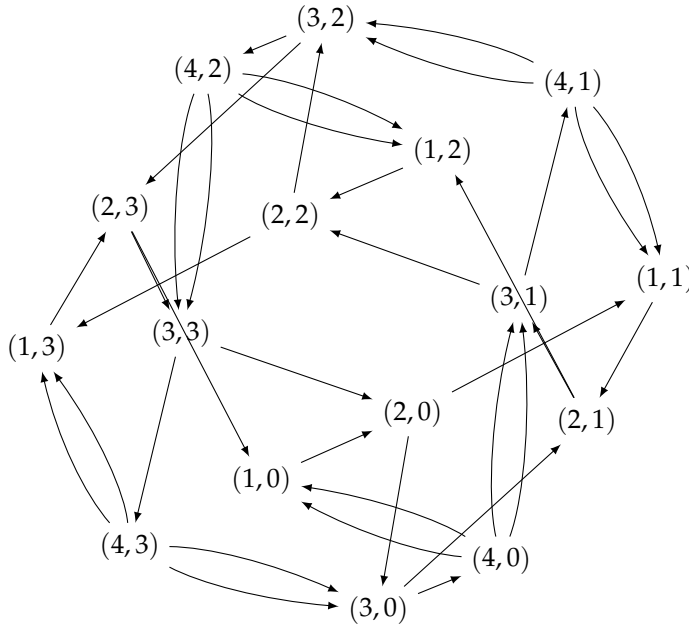

Figure 4.3: The McKay quiver of \mathcal{D}_4 at $V(2,0)$. McKay quivers of \mathcal{D}_n at $V(2,0)$ are the main example used by Benkart et al. It is noteworthy that these quivers are strongly connected, at least for all $1 \leq n < 1000$.

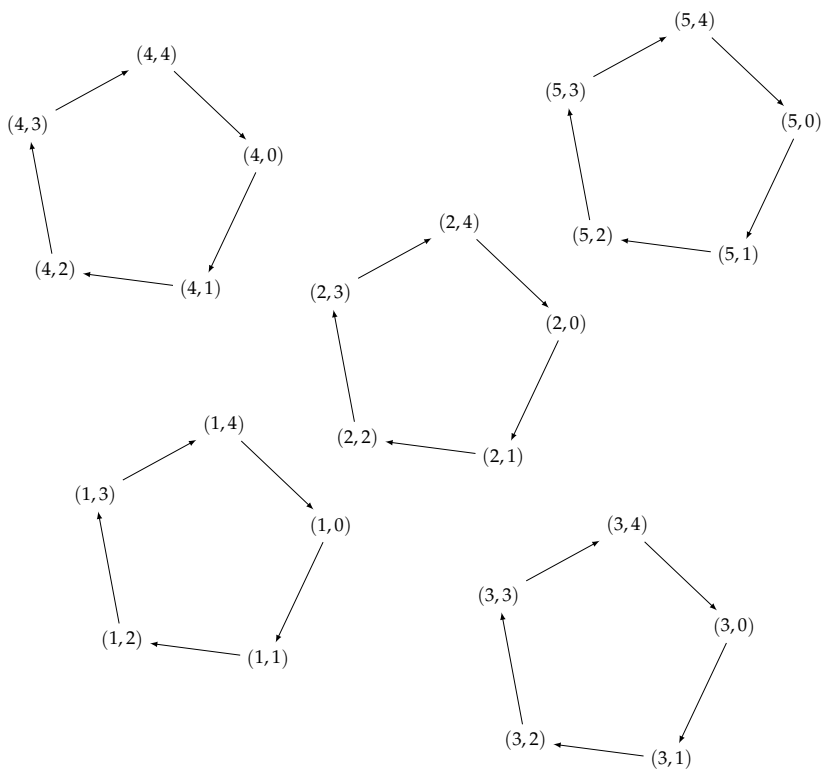

Figure 4.4: The McKay quiver of \mathcal{D}_5 at $V(1,1)$. At least for all $1 \leq n < 125$, the McKay quiver for \mathcal{D}_n at $V(1,1)$ is split into n connected components, each of which have vertices of all the same dimension.

5

Conclusion

We have seen how monoidal categories provide a natural environment for generalizing algebraic structures such as monoids, groups, and modules via the process of internalization. In particular, we have introduced the notion of a Hopf monoid in a symmetric monoidal category as the appropriate formulation of a group internal to a category lacking a canonical diagonal map, i.e. a non-cartesian category. We have also seen how the existence of rigid structure on a category \mathcal{C} implements a nice duality theory therein, allowing for the construction of internal homs and making \mathcal{C} equivalent to its reversed opposite $\mathcal{C}^{\text{rev,op}}$. We have developed the formalism of string diagrams in such categories and found it to be an essential tool both for exposition and proof.

We then reviewed the key features of the representation theory of groups, before exploring the adaptations necessary for the more general theory of finite-dimensional algebras which may not be semisimple. These include the theorems of Jordan-Hölder (theorem 3.15) and Krull-Schmidt (theorem 3.22). In §3.3 we gave an informal introduction of Tannaka duality as the study of the interplay of an algebraic structure and its category of representations. In doing so, we found a second motivation for Hopf algebras as the most general class of structures whose categories of representations are both monoidal and rigid under the tensor product.

Much of the representation theory of an algebra is captured by its Grothendieck rings, and we have seen how the monoidal structure and rigidity afforded by Hopf algebra structure is reflected here. In considering what the correct generalization of faithfulness for a Hopf algebra representation might be, §3.5 extended the work of Banica and Bichon by introducing bimonoid faithfulness as a strengthening of Hopf faithfulness, and we found these coincide in the case of a group algebra $\mathbb{K}G$ (proposition 3.35).

Finally we saw how the theory developed comes together in the study of McKay quivers of Hopf algebras. After stating conjecture 4.4, which suggests a condition for such a McKay quiver to be strongly connected, we investigated particular examples. With theorem 4.7 we saw the novel observation that the McKay quiver of the algebra \mathbb{K}^G of functions on a group G is naturally viewed as a Cayley graph of G , and with corollary 4.8 verified our conjecture

gives a necessary and sufficient condition for connectivity in this case. We then turned our attention to the noncommutative noncocommutative example of the Drinfel'd double \mathcal{D}_n of the Taft algebra \mathcal{H}_n . Thanks to the extensive work on the representations of \mathcal{D}_n by Chen et al., we are able to fully describe its Grothendieck groups $G_0\mathcal{D}_n$ and $K_0\mathcal{D}_n$ and use these to construct its McKay quivers, via a SageMath implementation presented in §B.

Some possible further work is apparent. First of all, there is the search for a proof of conjecture 4.4 either in general or a special case, such as the semisimple case. The discovery of such a proof would lend credence to bimonoid faithfulness as a good generalization of the faithfulness of group representations. Moreover, a proof of conjecture 4.4 would pave the way for a myriad other connectivity results about McKay quivers of Hopf algebras. Such a proof may call for a more thorough treatment of bimonoid faithfulness along the lines of that of Hopf faithfulness by Banica and Bichon,¹ including its behaviour with respect to Tannaka duality.² A second angle is the search for a general proof and explanation for the behaviour of the connected components of the McKay quivers of \mathcal{D}_n at both $V(2,0)$ and $V(2,1)$, as well as the computation of McKay quivers for other classes of Hopf algebras as completed for \mathcal{D}_n here.

¹ Banica and Bichon, "Hopf Images and Inner Faithful Representations."

² cf. Banica and Bichon, §8, pp. 695–98.

A

Abelian categories

Over an arbitrary ring R , the category ${}_R\text{Mod}$ has a number of desirable features already familiar from the special cases $\text{Vect}_{\mathbb{K}}$, $\text{Vect}_{(\mathbb{K})}$, and Ab .

- First, ${}_R\text{Mod}$ is what we call *enriched* over Ab : Each hom-set ${}_R\text{Mod}(V, W)$ is an abelian group under the addition $(f + g)(x) := f(x) + g(x)$.¹ Moreover, for any R -modules U, V, W the composition operation $(\circ) : {}_R\text{Mod}(U, V) \otimes {}_R\text{Mod}(V, W) \rightarrow {}_R\text{Mod}(U, W)$ defines a homomorphism of abelian groups.
- Finitary products and coproducts exist and coincide, given by the cartesian product with the natural R -action, inclusion, and projection, and called the **direct sum**. In particular, we have the *zero module* which is both initial and terminal.
- For any R -morphism $f : V \rightarrow W$ we can define the **image** $\bar{f} : V \twoheadrightarrow \text{im } f$, the **kernel** $\iota : \ker f \hookrightarrow V$, and the **cokernel** $\pi : W \twoheadrightarrow \text{coker } f := W / \text{im } f$.

This motivates the following definition:

Definition A.1. A **abelian category** is a category \mathcal{C} enriched over Ab which is equivalent to a full subcategory of ${}_R\text{Mod}$ for some ring R , which is itself closed under finitary direct sums, as well as the images, kernels, and cokernels of morphisms.²

Proposition A.2. Let A_1, \dots, A_n, B be objects in an abelian category \mathcal{C} . Then

$$\mathcal{C} \left(\bigoplus_{i=1}^n A_i, B \right) \cong_{\mathbb{Z}} \bigoplus_{i=1}^n \mathcal{C}(A_i, B).$$

Proof. The general case follows inductively from the case $\mathcal{C}(A_1 \oplus A_2, B) \cong_{\mathbb{Z}} \mathcal{C}(A_1, B) \oplus \mathcal{C}(A_2, B)$, which we will prove. Let $\varphi : \mathcal{C}(A_1 \oplus A_2, B) \rightarrow \mathcal{C}(A_1, B) \oplus \mathcal{C}(A_2, B)$ be the map defined by $\varphi(f) = (f\iota_1, f\iota_2)$. Then φ is a morphism in Ab since \mathcal{C} is Ab -enriched. Moreover, if $(f, g) = \varphi(h)$, then $h(a, b) = \{f, g\}(a, b) = f(a) + g(b)$, whence φ is an isomorphism of abelian groups. \square

In an abelian category \mathcal{C} , a **chain complex** $A = (A_{\bullet}, B_{\bullet})$ is a \mathbb{Z} -indexed sequence

$$\cdots \xrightarrow{\partial_{-k+1}} A_{-k} \xrightarrow{\partial_{-k}} A_{-k-1} \xrightarrow{\partial_{-k-1}} A_{-k-2} \xrightarrow{\partial_{-k-2}} \cdots$$

¹ Verifying that $f + g \in {}_R\text{Mod}(V, W)$ for $f, g \in {}_R\text{Mod}(V, W)$ is routine.

² This is not the standard definition of an abelian category, which would take too long to state. What we have presented here is more properly viewed as a consequence of the Freyd-Mitchell embedding theorem. The more abstract definition and treatment of what follows is given in Aluffi, *Algebra*, §§IX.1–2, pp.560–91. See also Mac Lane, *Categories for the Working Mathematician*, 191ff. Richter, *From Categories to Homotopy Theory*, 141ff.

of objects $A_{-k} \in \mathcal{C}$ with morphisms $\partial_{-k} : A_{-k} \rightarrow A_{-k-1}$ called **boundary operators** such that $\partial_{-k}\partial_{-k+1} = 0$ for all $k \in \mathbb{Z}$. We say A is **exact** or an **exact sequence** iff $\text{im } \partial_{-k} = \ker \partial_{-k-1}$ for all $k \in \mathbb{Z}$. A short exact sequence is an exact sequence of the form

$$\cdots 0 \rightarrow 0 \rightarrow A \xrightarrow{f} B \xrightarrow{g} C \rightarrow 0 \rightarrow 0 \rightarrow \cdots .$$

It follows that f and g are an epimorphism and monomorphism respectively, so we typically write $0 \rightarrow A \hookrightarrow B \twoheadrightarrow C \rightarrow 0$. Thus a short exact sequence gives an isomorphism $C \cong B/A$. Short exact sequences will feature extensively in §3.

Given two chain complexes $A = (A_\bullet, \partial_\bullet)$ and $A' = (A'_\bullet, \partial'_\bullet)$, a **chain map** is a \mathbb{Z} -indexed sequence of homomorphisms $f_k : A_k \rightarrow A'_k$ such that

$$\begin{array}{ccccccccc} \cdots & \xrightarrow{\partial_{-k+2}} & A_{k+1} & \xrightarrow{\partial_{-k+1}} & A_k & \xrightarrow{\partial_{-k}} & A_{k-1} & \xrightarrow{\partial_{-k-1}} & \cdots \\ & & \downarrow f_{-k+1} & & \downarrow f_{-k} & & \downarrow f_{-k-1} & & \\ \cdots & \xrightarrow{\partial'_{-k+2}} & A'_{-k+1} & \xrightarrow{\partial'_{-k+1}} & A'_{-k} & \xrightarrow{\partial'_{-k}} & A'_{-k-1} & \xrightarrow{\partial'_{-k-1}} & \cdots \end{array}$$

commutes for all $k \in \mathbb{Z}$. One can thus form the category $\text{Ch}_{\mathcal{C}}$ of chain complexes in \mathcal{C} together with chain maps.. Isomorphic chain complexes are called **equivalent**.

It is also possible to define the **direct sum complex** $A \oplus A'$ so that the $-k$ th object is $A_{-k} \oplus A'_{-k}$ and the $-k$ th boundary operator is $\partial_{-k} \oplus \partial'_{-k}$.

Proposition A.3. *Let $A = (A_\bullet, \partial_\bullet)$ and $(A'_\bullet, \partial'_\bullet)$ be chain complexes. Then $A \oplus A'$ is exact iff A and A' are exact.*

Proof. Note that $\ker(\partial_k \oplus \partial'_k) = (\ker \partial_k) \oplus (\ker \partial'_k)$. Similarly $\text{im}(\partial_{k-1} \oplus \partial'_{k-1}) = (\text{im } \partial_{k-1}) \oplus (\text{im } \partial'_{k-1})$. □

Lemma A.4 (Five lemma). *In an abelian category \mathcal{C} , suppose*

$$\begin{array}{ccccccccc} A_1 & \xrightarrow{\alpha_1} & A_2 & \xrightarrow{\alpha_2} & A_3 & \xrightarrow{\alpha_3} & A_4 & \xrightarrow{\alpha_4} & A_5 \\ \downarrow \gamma_1 & & \updownarrow \gamma_2 & & \downarrow \gamma_3 & & \updownarrow \gamma_4 & & \downarrow \gamma_5 \\ B_1 & \xrightarrow{\beta_1} & B_2 & \xrightarrow{\beta_2} & B_3 & \xrightarrow{\beta_3} & B_4 & \xrightarrow{\beta_4} & B_5 \end{array}$$

commutes where both rows are exact, γ_2, γ_4 are isomorphisms, γ_1 is an epimorphism, and γ_5 is a monomorphism. Then γ_3 is an isomorphism.

Proof. We prove the so-called five lemma by proving two “four lemmata” by diagram chasing in the equivalent subcategory of $R\text{Mod}$.

First we use the fact that γ_2, γ_4 are epic and γ_5 is a monomorphism to show that γ_3 is an epimorphism. Let $b_3 \in B_3$.

1. By the epimorphism property, $\gamma_4(a_4) = \beta_3(b_3)$ for some $a_4 \in A_4$.

2. By commutativity, $\beta_4\gamma_4(a_4) = \gamma_5\alpha_5(a_4)$.
3. By exactness, $0 = \beta_4\beta_3(b_3) = \beta_4\gamma_4(a_4) = \gamma_5\alpha_4(a_4)$.
4. By the monomorphism property, $\alpha_4(a_4) = 0$.
5. By exactness, $a_4 \in \ker \alpha_4 = \text{im } \alpha_3$.
6. Thus $a_4 = \alpha_3(a_3)$ for some $a_3 \in A_3$.
7. Thus $\beta_3\gamma_3(a_3) = \gamma_4\alpha_3(a_3) = \gamma_4(a_4) = \beta_3(b_3)$.
8. Thus $\beta_3(b_3) - \beta_3\gamma_3(a_3) = 0$.
9. By the homomorphism property, $\beta_3(b_3 - \gamma_3(a_3)) = 0$.
10. By exactness, $b_3 - \gamma_3(a_3) \in \ker \beta_3 = \text{im } \beta_2$.
11. Thus $b_3 - \gamma_3(a_3) = \beta_2(b_2)$ for some $b_2 \in \beta_2$.
12. By the epimorphism property, $b_2 = \gamma_2(a_2)$ for some $a_2 \in A_2$.
13. By commutativity, $\beta_2\gamma_2(a_2) = \gamma_3\alpha_2(a_2) = b_3 - \gamma_3(a_3)$.
14. By the homomorphism property, $\gamma_3(\alpha_2(a_2) + a_3) = \gamma_3\alpha_2(a_2) + \gamma_3(a_3) = b_3 - \gamma_3(a_3) + \gamma_3(a_3) = b_3$.

Therefore γ_3 is an epimorphism.

Now we will use the fact that γ_2, γ_4 are a monomorphism and γ_1 is an epimorphism to show that γ_3 is a monomorphism. Let $a_4 \in \ker \gamma_3$, so $\gamma_3(a_3) = 0$.

1. By the homomorphism property, $\beta_3\gamma_3(a_3) = 0$
2. By commutativity, $\gamma_4\alpha_3(a_3) = 0$.
3. By the monomorphism property, $\alpha_3(a_3) = 0$.
4. By exactness, $a_3 \in \ker \alpha_3 = \text{im } \alpha_2$.
5. Thus $a_3 = \alpha_2(a_2)$ for some $a_2 \in A_2$.
6. By commutativity, $\beta_2\gamma_2(a_2) = \gamma_3\alpha_2(a_2) = \gamma_3(a_3) = 0$.
7. By exactness, $\gamma_2(a_2) \in \ker \beta_2 = \text{im } \beta_1$.
8. Thus $\gamma_2(a_2) = \beta_1(b_1)$ for some $b_1 \in B_1$.
9. By the epimorphism property, $b_1 = \gamma_1(a_1)$ for some $a_1 \in A_1$.
10. By commutativity, $\gamma_2\alpha_1(a_1) = \beta_1\gamma_1(a_1) = \gamma_2(a_2)$.
11. By the monomorphism property, $\alpha_1(a_1) = a_2$.
12. By exactness $\alpha_2\alpha_1(a_1) = \alpha_2(a_2) = a_3 = 0$.

Therefore γ_3 is a monomorphism, and combined with the previous result, γ_3 is an isomorphism in ${}_R\text{Mod}$ and thus in \mathcal{C} . \square

Corollary A.5. *Two short exact sequences $0 \rightarrow A \hookrightarrow B \twoheadrightarrow C \rightarrow 0$ and $0 \rightarrow A \hookrightarrow B' \twoheadrightarrow C \rightarrow 0$ are equivalent iff there exists a morphism $f : B \rightarrow B'$ which along with the identities forms a chain map.*

A direct sum $A \oplus C$ induces a short exact sequence

$$0 \rightarrow A \xrightarrow{\iota_1} A \oplus C \xrightarrow{\pi_2} C \rightarrow 0$$

where we omit labelling the morphisms when the context makes it clear.

Definition A.6. A short exact sequence

$$0 \rightarrow A \xrightarrow{f} B \xrightarrow{g} C \rightarrow 0$$

is called **split** iff any of the following equivalent conditions hold:

1. the sequence is equivalent to one of the form $0 \rightarrow A \hookrightarrow A \oplus C \rightarrow C \rightarrow 0$ as shown in fig. A.1;
2. g is a split epimorphism; or
3. f is a split monomorphism.

Proof of equivalence. (1 \Rightarrow 2). Suppose the diagram in fig. A.1. The morphism π_2 splits with section $\iota_2 : C \hookrightarrow A \oplus C$. Then $g\beta^{-1}\iota_2 = \pi_2\iota_2 = 1_C$, so g is a split epimorphism.

(2 \Rightarrow 3). Suppose g has a section s so that $gs = 1_C$. Since $f : A \hookrightarrow B$ is injective, there exists an inverse on its range $f' : \ker g \rightarrow A$. Also, $b - sg(b) \in \ker g$ for all $b \in B$ since $g(b - rg(b)) = g(b) - grg(b) = g(b) - g(b) = 0$. Thus we may define $q(b) = f'(b - rg(b))$, which is a retraction of f since $qf(a) = f'(f(a) - rgf(a)) = f'(f(a) - r(0)) = a$ for all $a \in A$. Therefore f is a split monomorphism.

(3 \Rightarrow 1). Let q be a retraction of f so $qf = 1_A$. Let $\beta = (q, g) : B \rightarrow A \oplus C$. Then β makes fig. A.1 commute since $\beta f = (q, g)f = (qf, gf) = (1_A, 0) = \iota_1$ and $\pi_2\beta = \pi_2(q, g) = g$. □

A functor $F : C \rightarrow D$ between abelian categories is called **additive** iff it induces homomorphisms of abelian groups on hom-sets. Such a functor is called **left exact** iff for any exact sequence $0 \rightarrow A \rightarrow B \rightarrow C$ the sequence $0 \rightarrow FA \rightarrow FB \rightarrow FC$ is exact, and **right exact** iff for any exact sequence $A \rightarrow B \rightarrow C \rightarrow 0$ the sequence $FA \rightarrow FB \rightarrow FC \rightarrow 0$ is exact. An **exact** functor is both left and right exact. The following result is useful for proving exactness, though unfortunately more theory would be required to prove it.

Proposition A.7. Let $F \dashv G : C \rightarrow D$ be adjoint functors between abelian categories. Then F is right exact and G is left exact.³

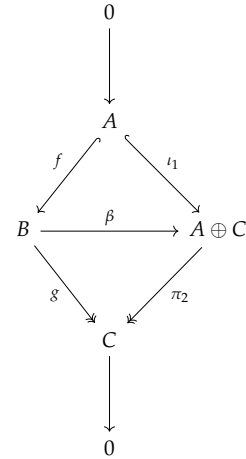

Figure A.1: A split exact sequence by condition 1 and corollary A.5.

³ Etingof et al., *Introduction to Representation Theory*, §7.9, pp. 194–95.

B

SageMath code

The quivers drawn in this thesis were created using code written in SageMath and interfacing with GAP.¹

The following implements the Grothendieck group $G_0\text{CG}$ for a finite group G using character theory.²

```
1 def reorder_CT(CT):
2     """For some reason GAP is not consistent in the order of character
3     tables, this fixes that by making sure the trivial character is first
4     and they are otherwise sorted by dimension"""
5     n = CT.dimensions()[0]
6     without_trivial = sorted(
7         (
8             row
9             for row in CT
10            if not all(i == 1 for i in row)
11        ),
12        key = lambda row: row[0]
13    )
14    return matrix([
15        [1 for i in range(n)],
16        *without_trivial
17    ])
18
19 def dimensions_CT(CT):
20     """Character table with two indices, so that a character is labelled
21     by (d,i) where d is the dimension"""
22     result = dict()
23     for  $\chi$  in CT:
24         d =  $\chi$ [0]
25          $\chi$ s = result.setdefault(d, list())
26          $\chi$ s.append( $\chi$ )
27     return dict(flatten([
28         [
29             ((d, i),  $\chi$ )
30             for (i,  $\chi$ ) in enumerate( $\chi$ s)
31         ]
32         for (d,  $\chi$ s) in result.items()
33     ], max_level = 1))
34
35 class FusionGroup(CombinatorialFreeModule):
36     """
37     The representation ring  $K_0(KG)$  for a permutation group  $G$ .
38     """
39     def __init__(self, G):
40         self.G = G
41         normal_CT = reorder_CT(self.G.character_table())
42         self.CT = dimensions_CT(normal_CT)
43         self.n = normal_CT.dimensions()[0] # number of conjugacy classes
```

¹ The SageMath Developers, *SageMath*; The GAP Group, *Groups Algorithms Programming*.

² All code is available online at <https://gist.github.com/jajaperson/a9e164895d128obba3efbf961d097244>

```

43     CombinatorialFreeModule.__init__(self, ZZ, list(self.CT.keys()),
category = AlgebrasWithBasis(ZZ), prefix = 'V')
44
45     def one_basis(self):
46         return (1,0)
47
48     def product_on_basis(self, left, right):
49          $\chi_1 = \text{self.CT}[\text{left}]$ 
50          $\chi_2 = \text{self.CT}[\text{right}]$ 
51          $\eta = \chi_1.\text{pairwise\_product}(\chi_2)$ 
52         return self.from_vector(vector(self._B( $\eta$ ,  $\chi$ ) for  $\chi$  in self.CT.
values()))
53
54     def _B(self,  $\chi_1, \chi_2$ ):
55         """Inner product on characters"""
56         sizes = [k.cardinality() / self.G.order() for k in self.G.
conjugacy_classes()]
57         return sum(sizes[i] *  $\chi_1[i].\text{conjugate}()$  *  $\chi_2[i]$  for i in range(
self.n))
58
59     def _repr_(self):
60         return "The representation ring  $G_0\mathbb{K}G$  for  $G = \%s$ " % (self.G)

```

Since the Grothendieck group $G_0\mathbb{K}^G$ for a finite group G is just $\mathbb{Z}G$, this is implemented as follows:

```

1 def FusionCayley(G):
2     """
3     The representation ring of the algebra of functions on a finite group
4     , which is just the integral group algebra.
5     """
6     return G.algebra(ZZ)

```

The following implements the Grothendieck group $G_0\mathcal{D}_n$ for the Drinfel'd double of the Taft algebra \mathcal{H}_n , as described in §4.3.2.

```

1 def  $\kappa(\tau)$ :
2     return floor(( $\tau+1$ ) / 2)
3
4 class FusionDoubleTaft:
5     """
6     Contains the Grothendieck rings  $K_0(\mathcal{D}_n)$  and  $G_0(\mathcal{D}_n)$  for the Drinfel'd
double  $\mathcal{D}_n$  of the Taft algebra, see
@benkartMcKayMatricesFinitedimensional2022,
@chenIndecomposableDecompositionTensor2017.
7
8     Note both of these needed to be defined together, hence the bundling
into one outer-class.
9     """
10
11     def __init__(self, n):
12         self.n = n
13         self.Zn = IntegerModRing(n)
14         self.atom_index = flatten([
15             [
16                 (i + 1, j)
17                 for j in self.Zn
18             ]
19             for i in range(n)
20         ], max_level = 1)
21         self.K0 = self._K0(self)
22         self.G0 = self._G0(self)
23         self.cartan = self.K0.module_morphism(
24             codomain = self.G0,
25             on_basis = self.cartan_on_basis
26         )
27
28     def V(self, l,r):

```

```

29     return self.G0.basis()[l,self.Zn(r)]
30
31     def P(self, l, r):
32         return self.K0.basis()[l,self.Zn(r)]
33
34     def cartan_on_basis(self, x):
35         V = self.V
36         n = self.n
37         (l,r) = x
38         if l == n:
39             return V(l,r)
40         else:
41             return 2 * V(l,r) + 2 * V(n - l, l + r)
42
43     class _K0(CombinatorialFreeModule):
44         def __init__(self, outer):
45             self.outer = outer
46             CombinatorialFreeModule.__init__(self, ZZ, self.outer.
atom_index, prefix = 'P')
47
48     class _G0(CombinatorialFreeModule):
49         def __init__(self, outer):
50             self.outer = outer
51             CombinatorialFreeModule.__init__(self, ZZ, self.outer.
atom_index, category = AlgebrasWithBasis(ZZ), prefix = 'V')
52
53     def one_basis(self):
54         return (1,0)
55
56     def product_on_basis(self, left, right):
57         # See proposition 3.1 of
@chenIndecomposableDecompositionTensor2017.
58         if right[0] < left[0]:
59             (left, right) = (right, left)
60
61         (l, r) = left
62         (l_, r_) = right
63
64         n = self.outer.n
65         cartan = self.outer.cartan
66         P = self.outer.P
67         V = self.outer.V
68
69         if l + l_ <= n + 1:
70             return sum(
71                 V(l + l_ - 1 - 2 * i, r + r_ + i)
72                 for i in range(l)
73             )
74         else:
75             tau = l + l_ - (n + 1)
76             proj_part = sum(
77                 P(l + l_ - 1 - 2 * i, r + r_ + i)
78                 for i in range(kappa(tau), tau + 1)
79             )
80             simp_part = sum(
81                 V(l + l_ - 1 - 2 * i, r + r_ + i)
82                 for i in range(tau + 1, l)
83             )
84             return cartan(proj_part) + simp_part
85
86     def _repr_(self):
87         return "The Grothendieck ring G0(D_n) for n = %s" % (self.
outer.n)

```

Bibliography

- Abramsky, Samson. "No-Cloning in Categorical Quantum Mechanics." In *Semantic Techniques in Quantum Computation*, edited by Ian Mackie and Simon Gay, 1–28. Cambridge: Cambridge University Press, 2009. ISBN: 978-0-521-51374-6. <https://doi.org/10.1017/CBO9781139193313.002>.
- Aguiar, Marcelo, and Swapneel Mahajan. *Monoidal Functors, Species, and Hopf Algebras*. CRM Monograph Series, Volume 29. Providence, Rhode Island: American Mathematical Society, 2010. ISBN: 978-0-8218-4776-3 978-1-4704-1768-0.
- Aluffi, Paolo. *Algebra: Chapter 0*. Graduate Studies in Mathematics, volume 104. Providence (R.I.): American mathematical society, 2009. ISBN: 978-0-8218-4781-7.
- Alvarez-Picallo, Mario, Dan Ghica, David Sprunger, and Fabio Zanasi. "Rewriting for Monoidal Closed Categories." In *7th International Conference on Formal Structures for Computation and Deduction (FSCD 2022)*, edited by Amy P. Felty, vol. 228, 29:1–29:20. Leibniz International Proceedings in Informatics (LIPIcs). Dagstuhl, Germany: Schloss Dagstuhl – Leibniz-Zentrum für Informatik, 2022. ISBN: 978-3-95977-233-4. <https://doi.org/10.4230/LIPIcs.FSCD.2022.29>.
- Awodey, Steve. *Category Theory*. 2nd ed. Oxford Logic Guides 52. Oxford; New York: Oxford University Press, 2010. ISBN: 978-0-19-958736-0.
- Baez, John C., and James Dolan. "Higher-Dimensional Algebra III: n -Categories and the Algebra of Opetopes." *Advances in Mathematics* 135, no. 2 (May 10, 1998): 145–206. ISSN: 0001-8708. <https://doi.org/10.1006/aima.1997.1695>.
- Baez, John C., and Mike Stay. "Physics, Topology, Logic and Computation: A Rosetta Stone." In *New Structures for Physics*, edited by Bob Coecke, 95–172. Berlin, Heidelberg: Springer, 2011. ISBN: 978-3-642-12821-9. https://doi.org/10.1007/978-3-642-12821-9_2.

- Banica, Teodor, and Julien Bichon. "Hopf Images and Inner Faithful Representations." *Glasgow Mathematical Journal* 52, no. 3 (September 2010): 677–703. ISSN: 1469-509X, 0017-0895. <https://doi.org/10.1017/S0017089510000510>.
- Benkart, Georgia, Rekha Biswal, Ellen Kirkman, Van C. Nguyen, and Jieru Zhu. "McKay Matrices for Finite-Dimensional Hopf Algebras." *Canadian Journal of Mathematics* 74, no. 3 (June 2022): 686–731. ISSN: 0008-414X, 1496-4279. <https://doi.org/10.4153/S0008414X21000067>.
- Benkart, Georgia, Persi Diaconis, Martin W. Liebeck, and Pham Huu Tiep. "Tensor Product Markov Chains." *Journal of Algebra*, Special Issue in Memory of Kay Magaard, 561 (November 1, 2020): 17–83. ISSN: 0021-8693. <https://doi.org/10.1016/j.jalgebra.2019.10.038>.
- Browne, Hazel. "Connectivity Properties of McKay Quivers." *Bulletin of the Australian Mathematical Society* 103, no. 2 (April 2021): 182–194. ISSN: 0004-9727, 1755-1633. <https://doi.org/10.1017/S0004972720000957>.
- Buchweitz, Ragnar-Olaf. "From Platonic Solids to Preprojective Algebras via the McKay Correspondence." In *Jahresbericht 2012*, 18–28. Oberwolfach Vorlesung 2012. Mathematisches Forschungsinstitut Oberwolfach, 2013. <https://doi.org/10.14760/AREP-2012>.
- Burnside, William. *Theory of Groups of Finite Order*. Cambridge Library Collection — Mathematics. Cambridge: Cambridge University Press, 2012. ISBN: 978-1-108-05032-6. <https://doi.org/10.1017/CBO9781139237253>.
- Chan, Kenneth, Ellen Kirkman, Chelsea Walton, and James J. Zhang. "McKay Correspondence for Semisimple Hopf Actions on Regular Graded Algebras, I." *Journal of Algebra* 508 (August 15, 2018): 512–538. ISSN: 0021-8693. <https://doi.org/10.1016/j.jalgebra.2018.05.008>.
- . "McKay Correspondence for Semisimple Hopf Actions on Regular Graded Algebras. II." *Journal of Noncommutative Geometry* 13, no. 1 (March 11, 2019): 87–114. ISSN: 1661-6952. <https://doi.org/10.4171/jncg/305>.
- . "Quantum Binary Polyhedral Groups and Their Actions on Quantum Planes." *Journal für die reine und angewandte Mathematik (Crelles Journal)* 2016, no. 719 (October 1, 2016): 211–252. ISSN: 1435-5345. <https://doi.org/10.1515/crelle-2014-0047>.
- Chase, Stephen U., and Moss E. Sweedler. *Hopf Algebras and Galois Theory*. Vol. 97. Lecture Notes in Mathematics. Berlin, Heidelberg: Springer Berlin Heidelberg, 1969. ISBN: 978-3-540-04616-5 978-3-540-36134-3. <https://doi.org/10.1007/BFb0101433>.

- Chen, Hui-Xiang. "A Class of Noncommutative and Noncocommutative Hopf Algebras: The Quantum Version." *Communications in Algebra* 27, no. 10 (January 1999): 5011–5032. ISSN: 0092-7872, 1532-4125. <https://doi.org/10.1080/00927879908826745>.
- . "Finite-Dimensional Representations of a Quantum Double." *Journal of Algebra* 251, no. 2 (May 15, 2002): 751–789. ISSN: 0021-8693. <https://doi.org/10.1006/jabr.2002.9144>.
- . "Irreducible Representations of a Class of Quantum Doubles." *Journal of Algebra* 225, no. 1 (March 1, 2000): 391–409. ISSN: 0021-8693. <https://doi.org/10.1006/jabr.1999.8135>.
- . "Representations of a Class of Drinfeld's Doubles." *Communications in Algebra* 33, no. 8 (July 1, 2005): 2809–2825. ISSN: 0092-7872. <https://doi.org/10.1081/AGB-200065383>.
- Chen, Hui-Xiang, Hassen Suleman Esmael Mohammed, and Hua Sun. "Indecomposable Decomposition of Tensor Products of Modules over Drinfeld Doubles of Taft Algebras." *Journal of Pure and Applied Algebra* 221, no. 11 (November 1, 2017): 2752–2790. ISSN: 0022-4049. <https://doi.org/10.1016/j.jpaa.2017.01.007>.
- Coecke, Bob, and Aleks Kissinger. *Picturing Quantum Processes: A First Course in Quantum Theory and Diagrammatic Reasoning*. Cambridge, United Kingdom; New York, NY, USA: Cambridge University Press, 2017. ISBN: 978-1-107-10422-8.
- Connes, Alain. *Noncommutative Geometry*. San Diego: Academic Press, 1994. ISBN: 978-0-12-185860-5.
- Curtis, Charles W. *Pioneers of Representation Theory: Frobenius, Burnside, Schur, and Brauer*. History of Mathematics, vol. 15. Providence, R.I.: American Mathematical Society; London Mathematical Society, 1999. ISBN: 978-0-8218-9002-8.
- Cvitanović, Predrag. *Group Theory: Birdtracks, Lie's, and Exceptional Groups*. Princeton, N.J.: Princeton University Press, 2008. ISBN: 978-0-691-11836-9.
- De Felice, Giovanni. "Hopf Algebras in Quantum Computation," New College, University of Oxford, 2017. <https://www.cs.ox.ac.uk/people/bob.coecke/Giovanni>.
- Drinfel'd, V. G. "Quantum Groups." *Journal of Soviet Mathematics* 41, no. 2 (April 1, 1988): 898–915. ISSN: 1573-8795. <https://doi.org/10.1007/BF01247086>.

- Eilenberg, Samuel, and G. M. Kelly. "Closed Categories." In *Proceedings of the Conference on Categorical Algebra*, edited by Samuel Eilenberg, D. K. Harrison, Saunders Mac Lane, and Helmut Röhrl, 421–562. Berlin, Heidelberg: Springer Berlin Heidelberg, 1966. ISBN: 978-3-642-99904-8. <https://doi.org/10.1007/978-3-642-99902-4>.
- Eilenberg, Samuel, and Saunders Mac Lane. "General Theory of Natural Equivalences." *Transactions of the American Mathematical Society* 58, no. 2 (September 1945): 231. ISSN: 00029947. <https://doi.org/10.2307/1990284>. JSTOR: 1990284.
- Etingof, Pavel, Shlomo Gelaki, Dmitri Nikshych, and Victor Ostrik. *Tensor Categories*. Mathematical Surveys and Monographs, volume 205. Providence, Rhode Island: American Mathematical Society, 2015. ISBN: 978-1-4704-3441-0 978-1-4704-2024-6.
- Etingof, Pavel, Oleg Golberg, Sebastian Hensel, Tiankai Liu, Alex Schwendner, Dmitry Vaintrob, and Elena Yudovina. *Introduction to Representation Theory*. American Mathematical Soc., 2011. ISBN: 978-0-8218-5351-1. Google Books: RS6IAwAAQBAJ.
- Fox, Thomas. "Coalgebras and Cartesian Categories." *Communications in Algebra*, January 1, 1976. <https://doi.org/10.1080/00927877608822127>.
- Gabriel, Peter. "Unzerlegbare Darstellungen I." *manuscripta mathematica* 6, no. 1 (March 1, 1972): 71–103. ISSN: 1432-1785. <https://doi.org/10.1007/BF01298413>.
- Grinberg, Darij, Jia Huang, and Victor Reiner. "Critical Groups for Hopf Algebra Modules." *Mathematical Proceedings of the Cambridge Philosophical Society* 168, no. 3 (May 2020): 473–503. ISSN: 0305-0041, 1469-8064. <https://doi.org/10.1017/S0305004118000786>.
- Hertweck, Martin. "A Counterexample to the Isomorphism Problem for Integral Group Rings." *Annals of Mathematics* 154, no. 1 (2001): 115–138. ISSN: 0003-486X. <https://doi.org/10.2307/3062112>. JSTOR: 3062112.
- Hotz, Günter. "Eine Algebraisierung Des Syntheseproblems von Schaltkreisen I." *Elektronische Informationsverarbeitung und Kybernetik* 1, no. 3 (1965): 209–231.
- Joyal, André, and Ross Street. "An Introduction to Tannaka Duality and Quantum Groups." In *Category Theory*, edited by Aurelio Carboni, Maria Cristina Pedicchio, and Guiseppa Rosolini, 413–492. Berlin, Heidelberg: Springer, 1991. ISBN: 978-3-540-46435-8. <https://doi.org/10.1007/BFb0084235>.
- . "Braided Tensor Categories." *Advances in Mathematics* 102, no. 1 (November 1, 1993): 20–78. ISSN: 0001-8708. <https://doi.org/10.1006/aima.1993.1055>.

- . “Planar Diagrams and Tensor Algebra.” Unpublished manuscript, September 1988. <http://web.science.mq.edu.au/~street/PlanarDiags.pdf>.
- . “The Geometry of Tensor Calculus, I.” *Advances in Mathematics* 88, no. 1 (July 1, 1991): 55–112. ISSN: 0001-8708. [https://doi.org/10.1016/0001-8708\(91\)90003-P](https://doi.org/10.1016/0001-8708(91)90003-P).
- Kan, Daniel M. “Adjoint Functors.” *Transactions of the American Mathematical Society* 87, no. 2 (1958): 294–329. ISSN: 0002-9947. <https://doi.org/10.2307/1993102>. JSTOR: 1993102.
- Kashaev, Rinat. “The Quantum Double.” In *A Course on Hopf Algebras*, 93–124. Universitext. Cham: Springer International Publishing, 2023. ISBN: 978-3-031-26305-7 978-3-031-26306-4. https://doi.org/10.1007/978-3-031-26306-4_5.
- Larson, Richard Gustavus. “Characters of Hopf Algebras.” *Journal of Algebra* 17, no. 3 (March 1971): 352–368. ISSN: 00218693. [https://doi.org/10.1016/0021-8693\(71\)90018-4](https://doi.org/10.1016/0021-8693(71)90018-4).
- Leinster, Tom. “The Bijection between Projective Indecomposable and Simple Modules,” October 14, 2014. <https://doi.org/10.48550/arXiv.1410.3671>. arXiv: 1410.3671 [math].
- Lesniewski, Andrew. “Noncommutative Geometry.” *Notices of the American Mathematical Society* 44, no. 7 (August 1997): 800–805. ISSN: 0002-9920. <https://www.ams.org/notices/199707/lesniewski.pdf>.
- Lorenz, Martin. “Representations of Finite-Dimensional Hopf Algebras.” *Journal of Algebra* 188, no. 2 (February 1997): 476–505. ISSN: 00218693. <https://doi.org/10.1006/jabr.1996.6827>.
- Mac Lane, Saunders. *Categories for the Working Mathematician*. Graduate Texts in Mathematics 5. New York, NY: Springer New York, 1978. ISBN: 978-1-4419-3123-8. <https://doi.org/10.1007/978-1-4757-4721-8>.
- Marculli, Matilde, Noam Chomsky, and Robert C. Berwick. *Mathematical Structure of Syntactic Merge: An Algebraic Model for Generative Linguistics*. The MIT Press, August 5, 2025. ISBN: 978-0-262-38334-9. <https://doi.org/10.7551/mitpress/15811.001.0001>.
- McKay, John. “Graphs, Singularities, and Finite Groups.” In *The Santa Cruz Conference on Finite Groups*, edited by Bruce Cooperstein and Geoffrey Mason, 183–186. Proceedings of Symposia in Pure Mathematics, vol. 37. Providence, R.I: American Mathematical Society, 1980. ISBN: 978-0-8218-1440-6.
- Radford, David E. “The Order of the Antipode of a Finite Dimensional Hopf Algebra Is Finite.” *American Journal of Mathematics* 98, no. 2 (1976): 333–355. ISSN: 0002-9327. <https://doi.org/10.2307/2373888>. JSTOR: 2373888.

- Richter, Birgit. *From Categories to Homotopy Theory*. Cambridge Studies in Advanced Mathematics. Cambridge: Cambridge University Press, 2020. ISBN: 978-1-108-47962-2. <https://doi.org/10.1017/9781108855891>.
- Simpson, Stephen G. FOM: Russell Paradox for Naive Category Theory. May 11, 1999. <https://cs.nyu.edu/pipermail/fom/1999-May/003117.html>.
- Street, Ross. "Categorical Structures." In *Handbook of Algebra*, edited by M. Hazewinkel, 1:529–577. Handbook of Algebra. North-Holland, January 1, 1996. [https://doi.org/10.1016/S1570-7954\(96\)80019-2](https://doi.org/10.1016/S1570-7954(96)80019-2).
- Sweedler, Moss E. *Hopf Algebras*. Mathematics Lecture Note Series. New York, NY: Benjamin, 1969. ISBN: 978-0-8053-9254-8.
- The GAP Group. *Groups Algorithms Programming*. V. 4.8.2, February 22, 2016. <https://doi.org/10.5281/ZENODO.46625>.
- The SageMath Developers. *SageMath, the Sage Mathematics Software System*. V. 9.7, September 19, 2022. <https://doi.org/10.5281/ZENODO.593563>.
- Tubbenhauer, Daniel. "What Is... the Jordan-Hölder Theorem?" April 17, 2022. <https://www.dtubbenhauer.com/slides/representation-theory/7-jordan-hoelder.pdf>.
- Underwood, Robert G. *Fundamentals of Hopf Algebras*. Universitext. Cham: Springer International Publishing, 2015. ISBN: 978-3-319-18990-1. <https://doi.org/10.1007/978-3-319-18991-8>.
- Voiculescu, Dan-Virgil, Nicolai Stammeier, and Moritz Weber, eds. *Free Probability and Operator Algebras*. 1st ed. Vol. 1. Münster Lectures in Mathematics. EMS Press, July 31, 2016. ISBN: 978-3-03719-165-1 978-3-03719-665-6. <https://doi.org/10.4171/165>.
- Witherspoon, Sarah J. "The Representation Ring and the Centre of a Hopf Algebra." *Canadian Journal of Mathematics* 51, no. 4 (August 1, 1999): 881–896. ISSN: 0008-414X, 1496-4279. <https://doi.org/10.4153/CJM-1999-038-5>.

Symbols

\emptyset the empty set

Ab the category of abelian groups and homomorphisms 6

$\text{Aut}_{\mathcal{C}}(X)$ the automorphism group of an object X in a category \mathcal{C} 6

\mathfrak{B}_n the braid group on n strands 21

$\text{Bimon}_{\mathcal{C}}$ the category of bimonoids in \mathcal{C} 31

Br the braid category 22

\mathcal{C} a category 5

Cat the category of (small) categories and functors 8

$\text{Ch}_{\mathcal{C}}$ the category of chain complexes in \mathcal{C} 76

${}_{\mathcal{X}}^{\mathcal{C}}\text{Mod}$ the category of left X -modules and homomorphisms in a monoidal category \mathcal{C} 30

$\text{cod } f$ codomain of f 5

$\text{Comon}_{\mathcal{C}}$ the category of comonoids in \mathcal{C} 29

$D^{\mathcal{C}}$ category of functors from \mathcal{C} to D 9

Δ_n the n th iterated multiplication of a comonoid 38

$\text{dom } f$ domain of f 5

$\underline{0}$ the empty category 6, 13

$\text{End}_{\mathcal{C}}(X)$ the endomorphism monoid of an object X in a category \mathcal{C} 6

FinGrp the category of finite groups and homomorphisms 6

${}_{(R)}\text{Mod}$ the category of finitely generated R -modules and homomorphisms

FinSet the category of finite sets and functions 6

$GL(V)$ group of linear automorphisms for on a vector space V

$GL_n(\mathbb{K})$ group of $n \times n$ invertible matrices over a field \mathbb{K} .

Grp the category of groups and homomorphisms 6

$C(X, Y)$ the set of morphisms between X and Y in C 5

Hopf_C the category of hopf monoids in C 33

1_X the identity morphism on X , or the identity element of X 5

$\text{im}(\vartheta)$ the image of a map ϑ .

\mathcal{K} a commutative ring 3

$\text{Vect}_{(\mathbb{K})}$ the category of finite-dimensional \mathbb{K} -vector spaces and \mathbb{K} -linear maps. 6, 9

\mathbb{K} an algebraically closed field 3

$\text{Vect}_{\mathbb{K}}$ the category of \mathbb{K} -vector spaces and \mathbb{K} -linear maps. 6

${}_R\text{Mod}$ the category of left R -modules and homomorphisms 14

$(\mathcal{A})\text{Proj}$ the category of finitely generated projective left \mathcal{A} -modules and homomorphisms 52

Mon_C the category of monoids in C 27

$\text{Mor } C$ class of all morphisms in C

\mathbb{N} the natural numbers > 0

\mathbb{N}_0 natural numbers with ≥ 0

$\text{Ob}(C)$ the class of objects in C 5

C^{op} the opposite category of C 7, 22

Q the walking quiver 16

Alg_R the category of R -algebras and homomorphisms

$\text{rep}_V(\mathcal{B})$ the set of representative forms on \mathcal{B} induced by V 62

C^{rev} the reversed monoidal category of C 22

Ring the category of rings and homomorphisms 6

Mod_R the category of right R -modules and homomorphisms

UAlg_R the category of unital R -algebras and unital homomorphisms

Set the category of sets and functions 6

σ the antipode of a Hopf monoid 32

Top the category of topological spaces and continuous functions 6

$\underline{1}$ the trivial category 6, 7, 13

V^* the dual vector space of V 8

\underline{X} the structure X considered as a category

ϵ the counit of a comonoid 38

Abbreviations

AC the Axiom of Choice 6, 10, 15, 21

NBG von Neumann-Bernays-Gödel set theory 5

TG Tarski-Grothendieck set theory 5, 8

ZFC Zermelo-Fraenkel set theory with Choice 5

Index

- abelian category, 13, 75
- adjoint functor, *see* adjunction
- algebra of functions on a group, 44
- antihomomorphism, 28
- antipode, *see* antipous
- antipous, 32
- associativity, 5
- augmentation, 61
- automorphism, 6
- Axiom of Choice, 6, 10, 15, 21

- bifunctor, *see* multifunctor
- bimonoid, 31
- bimonoid faithful, 61
- bimonoid kernel, 62
- biideal, 43
- braid group, 21

- Cartan map, 56
- Cartan matrix, 56
- categorification
 - horizontal, 25
 - vertical, 19
- category, 5
 - autonomous, 36
 - cartesian, 21
 - cartesian closed, 34
 - closed, 19
 - closed monoidal, 34
 - cocartesian, 21
 - concrete, 6
 - empty, 6
 - monoidal, 19, 20
 - braided, 20
 - strict, 20
 - symmetric, 21
 - of abelian groups, 6, 13, 14
 - of categories, 8, 13
 - of chain complexes, 76
 - of finite groups, 6
 - of finite sets, 6
 - of finite-dimensional vector spaces, 6
 - of functors, 9
 - of groups, 6, 13
 - of modules, 14, 75
 - internal, 30
 - of projective left modules, 52
 - of rings, 6, 13
 - of sets, 6, 13
 - of topological spaces, 6
 - of vector spaces, 6, 14
 - skeleton of, 10
 - opposite, 7
 - pivotal, 36
 - reversed monoidal, 22
 - rigid, 36
 - small, 8
 - trivial, 6
- Cayley graph, 68
- chain complex, 75
- chain map, 76
- class, 5
- coherence theorem
 - for braided monoidal categories, 22
 - for monoidal categories, 20
 - for symmetric monoidal categories, 21
- commutative diagram, 9
- commutator, 44
- composition factor, 53
- contragredient representation, *see* dual representation
- convolution of morphisms, 31
- coproduct, 12
 - of categories, 7
 - of groups, 13
- coevaluation, 34, 35
- coideal, 42
- Curry-Howard-Lambek correspondence, 1
- currying, 34

- decomposition into indecomposable modules
 - see* Remak decomposition, 53
- decomposition into simple modules
 - see* Jordan-Hölder series, 53
- derivation, 44

- diagonal functor, 12
- direct sum
 - of chain complexes, 76
- division ring, 15
- Drinfel'd double, 45, 69
- dual bimonoid, 38
- dual representation, 50
- dual vector space, 8, 9
- duality in a monoidal category, 35
- dualizable object, 35

- endofunctor, 8
- endomorphism, 6
- epimorphism, 6
- equivalence of categories, 10
- equivalence of chain complexes, 76
- essential inverse, 10
- evaluation, 34, 35
- exact sequence, 76
- exponential object, 34
- extranatural transformation, 34

- Feynman diagram, 36
- fibre functor, 50
- forgetful functor, *see also* free-forgetful adjunction, 11
- free group, 11
- free \mathbb{K} -comonoid, 40
- free module, 15
- free product of groups, 8
- free-forgetful adjunction, 11, 15
- functor, 7, 11
 - additive, 78
 - contravariant, 7
 - faithful, 7
 - full, 7
 - monoidal, 22

- Grothendieck group, 55
 - group
 - as a category, 7, 8
 - group action, 8
 - group algebra, 41
 - group subalgebra, 41
 - grouplike, 39

- hom-functor, 8
- hom-set, 5
- homomorphism
 - of modules, 13
 - of quivers, 17
 - of representations, 49
- Hopf algebra, 32
- Hopf faithful, 61
- Hopf ideal, 43
- Hopf kernel, 62
- Hopf monoid, 32
 - autonomous, 32
 - involutive, 34
- horizontal composition, 25

- ideal, 41
- identity
 - functor, 7
 - morphism, 5
- image, 75
- Internal Axiom of Choice, 6
- internalization, 19
- invariant vector, 59
- isofunctor, 8, 14
- isomorphism, 6
 - class, 10
 - natural, 9
 - of categories, *see* isofunctor
- iterated comultiplication, 29
- iterated multiplication, 27

- Jacobi identity, 44
- Jordan-Hölder filtration, 52
- Jordan-Hölder series, 53
- Jordan-Hölder theorem, 53

- \mathcal{K} -algebra
 - unital associative, *see* \mathcal{K} -monoid
- \mathcal{K} -monoid, 24
- \mathbb{K} -monoid, 24
 - semisimple, 49
- Krull-Schmidt theorem, 54

- Leibniz rule, *see* derivation
- length of a module, 53
- Lie algebra, 43

- Maschke's theorem, 50
- module, 13
 - completely reducible, *see* semisimple module
 - decomposable, 49
 - indecomposable, 49
 - internalized, 30
 - irreducible, *see* simple module
 - semisimple, 49
 - simple, 49
 - trivial, 58
- monoid, 6
 - as a category, 7
 - in a monoidal category, 24, 26
 - opposite, 28
- monoid faithful module, 61
- monoidal equivalence of categories, 24
- monomorphism, 5
- morphism, 5, *see also* homomorphism 13
- multifunctor, 8
- multisets, 3

- natural inclusion, 12
- natural projection, 13
- natural transformation, 9
 - monoidal, 23
- object, 5
 - as a functor, 7, 12
 - as its identity, 5, 25
- orthogonal complement, 42

- permutation representation, 48
- Pontryagin duality, 57
- primitive element, 43
- product, 12
 - of categories, 7
 - of groups, 13
- projective cover, 55
- pullback
 - of a morphism, 8
- pushforward
 - of a morphism, 8

- quantization, 1
- quantum double, *see* Drinfel'd double
- quantum group, 2
- quotient Hopf \mathbb{K} -algebra, 43
- quotient \mathbb{K} -bimonoid, 43
- quotient \mathbb{K} -comonoid, 42
- quotient \mathbb{K} -monoid, 42
- quotient module, 14

- regular module, 13
- representation, *see also* module
 - faithful, 48
- representative form, 62
- retraction, 5
- Russel's paradox, 8

- section, 6
- short exact sequence
 - split, 78
- skeletal category, 6, 10
- skeleton, 10
- split epimorphism, 6
- split monomorphism, 5
- strictification theorem
 - for braided monoidal categories, 22
 - for monoidal categories, 20
 - for symmetric monoidal categories, 21
- string diagram, 25
- subcategory, 7
 - full, 7
- submodule, 14
- Sweedler notation, 38

- Taft algebra, 45, 69
- Tannaka duality, 57
- Tannaka reconstruction theorem, 57
- tensor product
 - of \mathcal{K} -modules, 15
 - of monoids, 27
- torsion, 14
- trivial module, 48
- trivial representation, 48

- undirected quiver, 17
- unit monoid, 27
- unit of adjunction, 12
- universal enveloping algebra, 44
- universal property, 11

- walking quiver, 16

- Yoneda lemma, 12